

Dear Customer,

We thank you for having chosen one of our products, the fruit of technological experience and of continual research for a superior quality product in terms of safety, dependability, and service. In this manual you will find all the information and useful suggestions to use your product with the maximum safety and efficiency.



We highly recommend to turn to our Authorized Service Centre for the installation and the first ignition of the device as it not only carries out the installation perfectly but also verifies the regular operation of it.

- Incorrect installation, incorrectly performed maintenance, improper use of the product release the manufacturer from every eventual damage derived from the use of the Hydro Insert.
- The unit cannot be used as an incinerator. Do not use fuels other than pellets.
- This manual has been realized by the manufacturer and constitutes an integral part of the product and must remain with it during its entire lifetime. If the product is sold or transferred, be sure that the booklet is present since the information contained in it are addressed to the buyer, and to all those persons of various titles who complete the installation, use and maintenance.
- Carefully read the instructions and the technical information contained in this manual, before proceeding with the installation, use, and any operation on the product.
- The observance of the indications contained in the present manual guarantees the safety of people and the product, the economy of use and a longer functioning lifetime.
- Although the carefully studied design and the risk analysis done by our company has permitted the realization of a safe product, in any case, before effecting any operation on the Hydro Insert, it is recommended to keep said manual available and pay scrupulous attention to the instructions written therein.
- Be very careful when moving the ceramic details where present.
- Check the precise flatness of the pavement where the product will be installed
- The wall where the product will be placed must not be constructed in wood, or in any case, made of an inflammable material, and in addition it is necessary to maintain a safety distance.
- While the Hydro Insert is in operation, several parts of the Hydro Insert (door, handle, sides) can reach high temperatures. Therefore pay attention and use the proper precautions, above all in the presence of children, elderly or disabled persons, and animals.
- Assembly must be performed by authorized persons (Authorized Assistance Center).
- Diagrams and drawings are furnished for the purpose of illustration; the manufacturer, with the intent of pursuing a policy of constant development and renewal of the product can, without any notice, make any modifications that are believed opportune.
- When the Hydro Insert is working at its maximum speed, it is strongly suggested to wear gloves while handling with the door for pellets loading and the door handle.
- It is prohibited to install in bedrooms or in explosive environments.
- Only use replacement parts recommended by the supplier.



Never cover the body of the Hydro Insert in any way or obstruct the openings placed on the upper side when the device is operating. All our Hydro Inserts are trial lighted on the construction line.

In the event of a fire, disconnect the power supply, use an extinguisher and call the fire fighters if necessary. After that contact the Authorized Assistance Center.

This instruction booklet is an integral part of the product: make sure that it always accompanies the appliance, even in case of transfer to another owner or in the case of transfer to another place. In the event of damage or loss, request a copy from the area technician.

These symbols indicate specific messages in this booklet:



ATTENTION: This warning sign indicates that the message to which it refers should be carefully read and understood, because failure to comply with what these notices say can cause serious damage to the Hydro Insert and put the user's safety at risk.



INFORMATION: This symbol is used to highlight information which is important for proper Hydro Insert operation. Failure to comply with these provision will compromise use of the Hydro Insert and its operation will not be satisfactory.

Norms and declarations of conformity

Our company declares that the Hydro Insert conforms to the following norms for the EC European Directive labelling:

- 2014/30 UE (regulation EMCD) and following amendments;
- 2014/35 UE (Low Voltage Directive) and following amendments;
- 2011/65 UE (RoHS 2 directive);
- The rules of Construction Products (CPR- Construction Products Regulation) No. 305/2011 regarding the construction world;
- For installations in Italy, please refer to UNI 10683/98 or following changes. For the water-thermo-sanitary equipment, let the installer give you the conformity declaration in compliance with L. 37/2008. While installing the unit respect the local, national and European rules;
- EN 55014-1; EN 55014-2; EN 61000-3-2; EN 61000-3-3; EN 60335-1; EN 60335-2-102; EN 62233, EN 50581.

Safety information

Please carefully read this use and maintenance manual before installing and operating the Hydro Insert!

If clarification is needed, please contact the dealer or the Authorized Assistance Center.

- The pellet Hydro Insert must only be operated in living environments. This Hydro Insert, being controlled by an electronic board, permits a completely automatic and controlled combustion; the exchange, in fact, regulates the lighting phase, 5 power levels and the shut down stage,

guaranteeing the safe operation of the Hydro Insert.

- The basket used for combustion allows most of the ash produced by the combustion of the pellets to fall into the collection compartment. Nevertheless, check the basket daily, given that not all pellets have high quality standards (use only quality pellets recommended by the manufacturer).

Responsibility

With the delivery of the present manual, we decline all responsibility, both civil and penal, for accidents deriving from the partial or total lack of observance of the instructions contained herein.

We decline every responsibility derived from improper use of the Hydro Insert, from incorrect use by the user, from unauthorized modifications and/or repairs, from the use of replacement parts that are not original for this model.

The manufacturer declines every civil or penal, direct or indirect responsibility due to:

- Lack of maintenance;
- Failure to observe the instructions contained in the manual;
- Use in non-conformity with the safety directives;
- Installation in non-conformity with the norms in force in the country;
- Installation by unqualified or untrained personnel;
- Modifications and repairs not authorized by the manufacturer;
- Use of non-original replacement parts;
- Exceptional events.



- Use only wood pellets;
- Keep / store the pellets in a cool dry place;
- Never pour pellets directly on the hearth;
- The Hydro Insert must only be fed with quality 6 mm diameter pellets, A1 certified according to the UNI EN ISO 17225-2 regulations;
- Before making the electrical connection of the Hydro Insert the discharge tubes must be connected with the flue;
- The protective grill placed inside the pellet container must never be removed;
- The environment where the Hydro Insert is installed must have a sufficient exchange of air;
- It is forbidden to operate the Hydro Insert with the door open or the glass broken;
- Do not use the Hydro Insert as an incinerator; the Hydro Insert should be used only for the intended purpose;
- Any other use is considered improper and therefore dangerous. Do not put in the hopper other than wood pellets;
- When the Hydro Insert is operating, the surfaces, glass, handle and tubes become very hot: during operation do not touch these parts without adequate protection;
- Keep the fuel and other inflammable materials off the Hydro Insert.

Charge pellet

Fuel is loaded from the upper part of the Hydro Insert by opening a door. Pour the pellets in the hopper.

This is easier if performed in two steps:

- Pour half of the contents of the bag into the hopper and wait for the fuel to settle on the bottom.
- Then pour in the second half;
- Keep the cover closed , after loading the pellets , the lid of the fuel tank;

The Hydro Insert is a product by heating, presents the external surfaces particularly hot. For this reason, we recommend extreme caution when operating in particular:

- Do not touch the Hydro Insert body and the various components, do not approach the door , it could cause burns;
- Do not touch the exhaust fumes;
- Do not perform any type of cleaning;
- Do not dump the ashes;
- Do not open the ash tray;
- Be careful that children do not come near;



Never remove the protection grille in the hopper. When filling, do not let the sack of pellets touch any hot surfaces.



EN Instructions for safe and efficient use

- The device can be used by children that are not less than 8 years old and people with reduced physical, sensory or mental capabilities, or lack of experience or knowledge, provided being under supervision of someone responsible or after having received instructions relating to the safe use of the device and to the understanding of the dangers inherent to it. Children should not play with the device. Cleaning and maintenance to be performed by the user should not be made by children without supervision;
- Do not use the Hydro Insert as a ladder or scaffold;
- Do not put clothes to dry on the Hydro Insert. Any clothes hangers and suchlike must be kept a suitable distance from the Hydro Insert. - Risk of fire
- Carefully explain that the Hydro Insert is made from material subjected to high temperatures for the elderly, the disabled, and in particular for all children, keeping them away from the Hydro Insert during operation
- Do not touch the Hydro Insert with wet hands: the Hydro Insert has electrical components that could produce sparks if handled incorrectly.
- Never open the glass door of the pellet Hydro Insert while the Hydro Insert is in operation
- The Hydro Insert must be connected to an electrical system equipped with an earthing conductor in accordance with regulations 73/23 and 93/98 EEC;
- The system must be of adequate electrical power declared the Hydro Insert;
- Do not wash the inside of the Hydro Insert with water. The water could damage the electrical insulation, causing electric shock;
- Do not expose your body to hot air for a long time. Do not overheat the room you are in and where the Hydro Insert is installed. This can damage the physical conditions and cause health problems;
- Do not expose to direct the flow of hot air plants or animals;
- The pellet Hydro Insert is not a cooking element;
- External surfaces during operation can become very hot. Do not touch them except with the appropriate protection.
- The plug of the device power cable must be connected only after installation and assembly of the device and must remain accessible after installation, if the unit is not provided of a double-pole switch suitable and accessible.
- Pay attention that the power cord (and any other cables external to the appliance) do not touch hot parts.
- Do not lay objects, glasses, infusers, room perfumers on the Hydro Insert, they could be damaged or to damage the Hydro Insert (in this case de warranty does not respond).

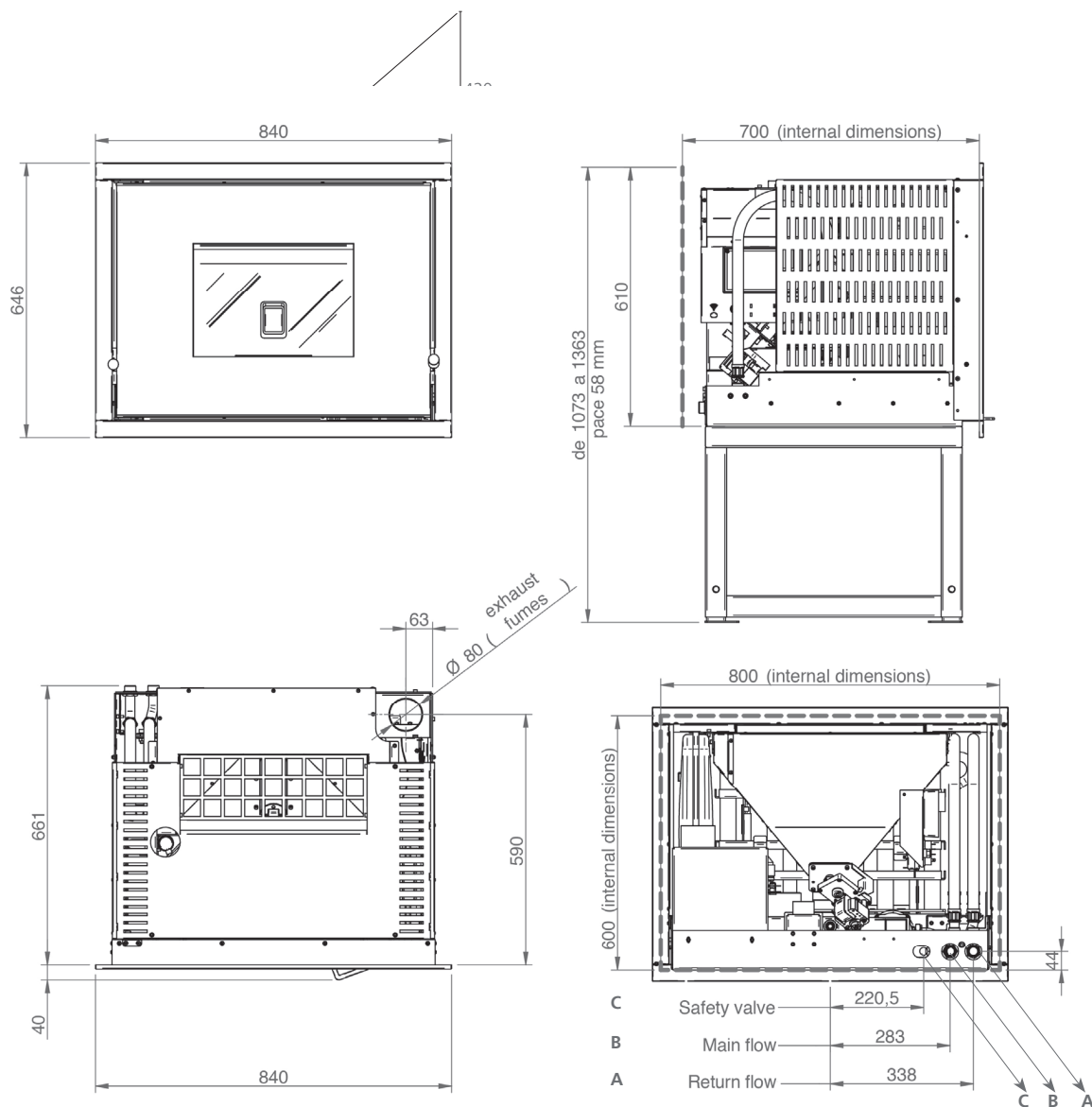

N.B.

- 1 - Measures with a tolerance of about 10 mm
- 2 - Measures and images are indicative and can vary depending on the aesthetic of the pellet Hydro Insert.

PARAMETER	M. UNITS	ICPHYDRO17	ICPHYDRO25
Heat input	kW	17,6	25,6
Nominal heat output	kW	16,5	23,6
Reduced heat output	kW	7,1	8,2
Water heat output	kW	13,1	19,2
Reduced water heat output	kW	5,1	7,9
CO concentration at nominal reference (13% O ₂)	mg/m ³	110	85
CO concentration at reduced reference (13% O ₂)	mg/m ³	116	109
Nominal efficiency	%	94,0	92,2
Reduced efficiency	%	96,3	95,8
Pellet consumption (min-max)	Kg/h	1,5 - 3,6	1,69 - 5,25
Heated surface	mc	300	450
Flue gas flow rate (min-max)	g/s	5,49 - 10,80	5,85 - 13,58
Draft (min-max)	Pa	3 - 10	3 - 12
Flue gas temperature (min-max)	°C	68,8 - 115,1	82,3 - 160,6
Hydro Insert water	litri	30	30
Maximum working pressure	bar	2,5	2,5
Tank capacity	Kg	22	22
Smoke outlet tube	mm	80	80
Diameter air intake	mm	50	50
Connecting heating	Inch	3/4"	3/4"
Nominal voltage	V	230	230
Nominal frequency	Hz	50	50
Power consumption max	W	320	320
Nominal Power consumption	W	75 -58	90 - 65
Hydro Insert weight	Kg	180	180
Hydro Insert weight with base	Kg	210	210
EEl		133	131
N° Test Report		K 2330 2018 T1	
Ambiental decree n.186		★★★★☆	
Energetic class		A++	
Dust at 13% O ₂ at nominal heat output	mg/m ³	14,9	17

It is recommended that the control of emissions after installation.

Operating area



It is not permissible to install the Hydro Insert in bedrooms, bathrooms, or in a room where another heating appliance is installed (Hydro insert, Hydro Insert etc.) which does not have its own independent air intake. Locating the Hydro Insert in a room with an explosive atmosphere is prohibited. The floor of the room where the Hydro Insert is to be installed must be strong enough to take its weight. Keep a minimum distance of 50 mm between the covering and the fireplace insert. If walls are flammable, maintain a minimum distance of (A) 450 mm, rear of (B) 300 mm, side of (C) 400 mm, front of (D) 1000 mm and from floor of (E) 450 mm. If the room contains objects which are believed to be particularly delicate, such as drapes, sofas and other furniture, their distance from the Hydro Insert should be considerably increased. The two side walls of the chimney insert must be accessible for maintenance by authorized technicians.

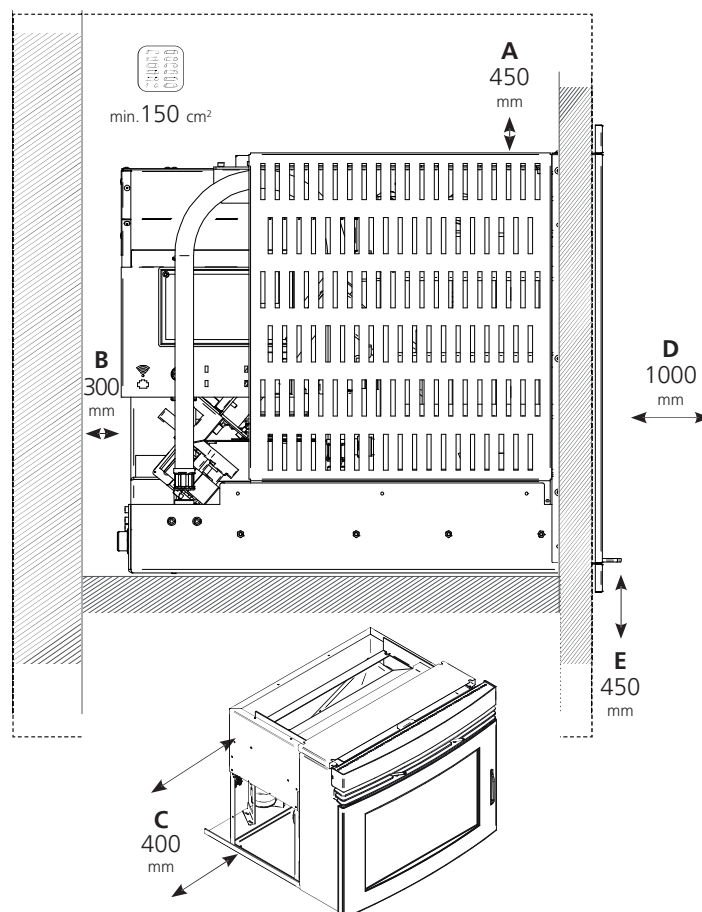

How to place the Hydro Insert

For proper functioning and a good temperature distribution, the Hydro Insert should be positioned in a location where it is able to take in the air necessary for combustion of the pellet (about 40 m³/h must be available), as laid down in the standard governing the installation and in accordance with local national standards.

The volume of the room must not be less than 30 m³.

The air must come in through permanent openings made in walls (in proximity to the Hydro Insert) which give onto the outside, with a minimum cross-section area of 100 cm².

These openings must be made in such a way that it is not possible for them to be obstructed in any way. Alternatively, the air can be taken from rooms adjacent to the one which needs ventilating, as long as they are provided with an air intake from the outside, and are not used as bedrooms or bathrooms, and provided there is no fire risk such as there is for example in garages, woodsheds, and storerooms, with particular reference to what is laid down in current standards.

Connection to the external air intake

It is essential that at least as much air must be able to flow into the room where the Hydro Insert is installed as is required for proper combustion in the appliance and for the ventilation of the room. This can be effected by means of permanent openings in the walls of the room to be ventilated, which give onto the outside, or by single or collective ventilation ducts.

For this purpose, on the external wall near the Hydro Insert, a hole must be made with a minimum free cross-section of 100 cm². (equivalent to a round hole of 12 cm diameter or a square hole 10x10 cm) protected by a grille on the inside and the outside.

The air intake must also: communicate directly with the room where the Hydro Insert is installed be protected by a grille, metal mesh or suitable guard, as long as this does not reduce the area below the minimum.

Be positioned in such a way as to be impossible to obstruct.

Connection to the flue pipe

The flue pipe must have internal dimensions not larger than 20x20 cm, or diameter 20 cm. In the event of larger dimensions, or of the flue pipe being in poor condition (for example cracks, poor insulation, etc.), it is advisable to fit a stainless steel pipe of suitable diameter inside the flue pipe throughout its length, right up to the top.

Check with suitable instruments that the draught is as shown in the table. This type of connection ensures the evacuation of the fumes even in the event of a temporary power cut.

At the bottom of the flue pipe, provide an inspection cap to allow periodic checking and cleaning, which must be done annually. Make a gas-tight connection to the flue pipe, using pipes and connectors as recommended by us.

You must ensure that a windproof cowl should be fitted which complies with the standards in force

Connection to an external flue with insulated or double-wall pipe

The only type of pipe which is permissible is insulated (double-walled) stainless steel, smooth on the inside, fixed to the wall. Flexible stainless steel pipe must not be used. At the bottom of the flue pipe, provide an inspection cap to allow periodic checking and cleaning, which must be done annually. Make a gas-tight connection to the flue pipe, using pipes and connectors as recommended by us. You must ensure that a windproof cowl should be fitted which complies with the standards in force.

Check with suitable instruments that the draught is as shown in the table.

Connection to the flue pipe

For proper functioning, the connecting pipe between the Hydro Insert and the chimney or flue duct must have a slope of not less than 3% in the horizontal stretches, the length of which must not exceed 2 metres and the vertical distance between one tee connector and another (change of direction) must not be less than 1,5 m.

Check with suitable instruments that the draught is as shown in the table. At the bottom of the flue pipe, provide an inspection cap to allow periodic checking and cleaning, which must be done annually. Make a gas-tight connection to the flue

pipe, using pipes and connectors as recommended by us. You must ensure that a windproof cowl should be fitted which complies with the standards in force.

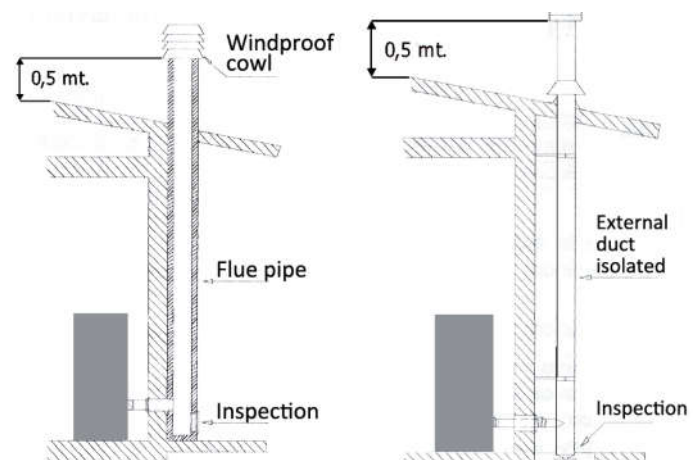
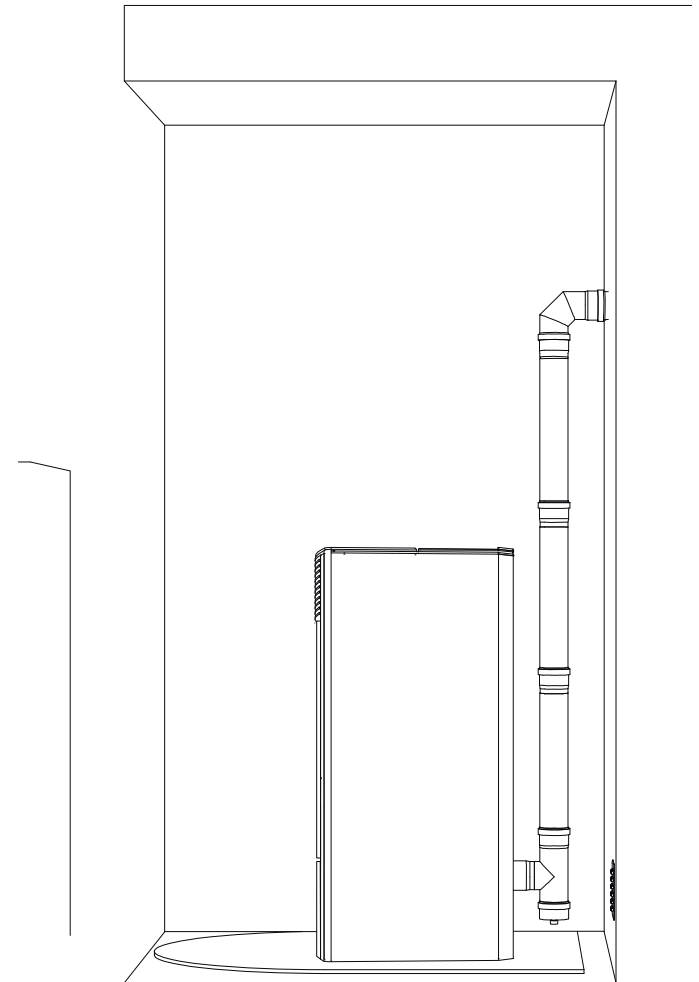

Fig. 2: connection to the flue pipe.

Fig. 3: connection to an external flue with insulated or double-wall pipe.

Fireplace flue gas

Avoid contact with combustible materials (example: wooden beams) and in any case provide for their insulation with flame retardant material. In case of pipe penetrations through roofs or walls is recommended to use special kits crossing, certificates, are available commercially. In the event of a chimney fire, turn off the Hydro Insert, disconnect from the network and never open the door. Then call the authorities.

The chimney cap

The chimney cap must respect the following requirements:

- It must have the equivalent diameter and internal form of the flue.
- It must have a useful outlet diameter of not less than double that of the flue.
- The chimney cap on the roof or that remains in contact with the outside (for example, in case of open lofts or attics), must be covered with elements in brick or tile and must, in any case, be well insulated.
- It must be constructed to prevent rain, snow, and extraneous bodies from entering the flue and so that the discharge of the products of combustion is not inhibited by wind from any quarter or strength (wind-proof chimney cap).
- The chimney cap must be positioned in such a way as to guarantee the adequate dispersion and dilution of the products of combustion and in any case, must be out of the reflux zone. This zone has different dimensions and forms according to the angle of inclination of the roof so it is necessary to adopt minimum heights (Fig. 2).
- The chimney cap must be a wind-proof type and must be above the ridge.
- Eventual structures or other obstacles that are higher than the chimney cap must not be too close to the chimney cap itself.
- The device should not be installed in the flue shared.

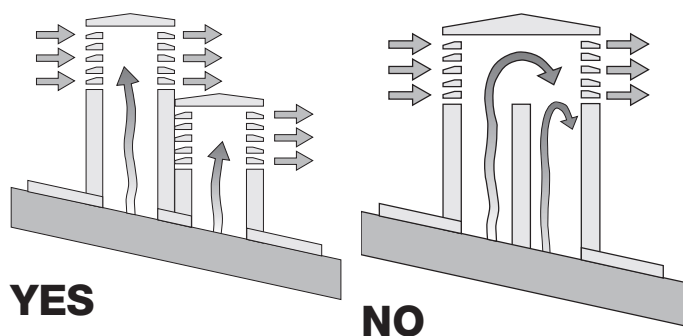

Characteristics of chimney

REMARKS:

- The appliance must be installed by a qualified technician in possession of the technical and professional requirements according to the DM37/2008 that, under its responsibility, to ensure compliance with the rules of good technique.
- The Hydro Insert must be connected to a heating system and/or to a network of production of sanitary hot water, consistent with its performance and its power.
- You need to keep in mind all laws and national, regional, provincial and municipal laws of the country in which you installed the device.
- Check that the floor is not flammable: if necessary use a suitable platform.
- In the room where the generator must be installed to heat must not pre-exist or be installed with an extractor hood or ventilation ducts of the collective type. Should these devices be located in adjacent rooms communicating with the installation, and 'prohibited the simultaneous use of the heat generator, where there is a risk that one of the two rooms being placed in depression than the other.
- It is not permissible to install in bedrooms or bathrooms.
- The card is equipped with an anti-freeze device. If the machine is switched off and the room temperature drops below the 4 °C, the device will start automatically.
- If the machine won't be used for a long time and there's a risk of freezing, we'll recommend to empty the device.

Hydro insert assembly

Hydro Insert fixing

If you have purchased the fireplace insert pedestal, first you have to fix it to the floor and choose the height of the legs. Fix the fireplace insert to the base or to the pedestal using the fixing screws (not supplied). **If the fireplace is already existing, the side openings for access must be provided.**

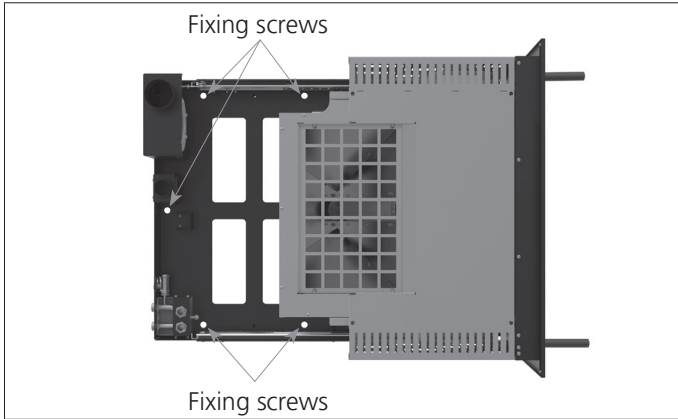

Pedestal fixing (Optional)

If you have bought the fireplace insert pedestal, first you have to fix it to the floor and choose the height of the legs. If you install the lateral load, it is advisable to keep the minimum size so as not to have the loading entrance too high.

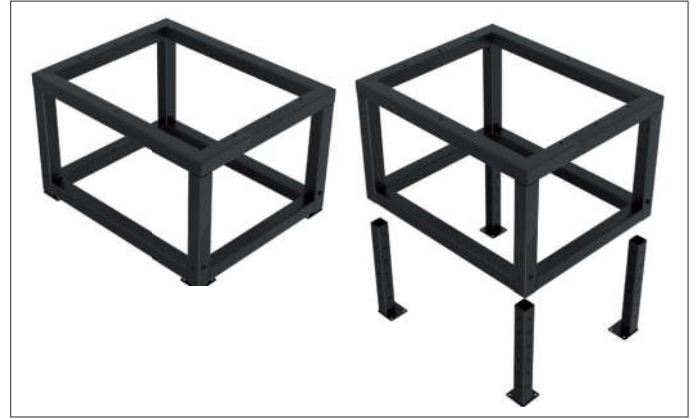

Side loading system (Optional)

The assembly of the side loading system must be done before the construction of the fireplace insert coating.

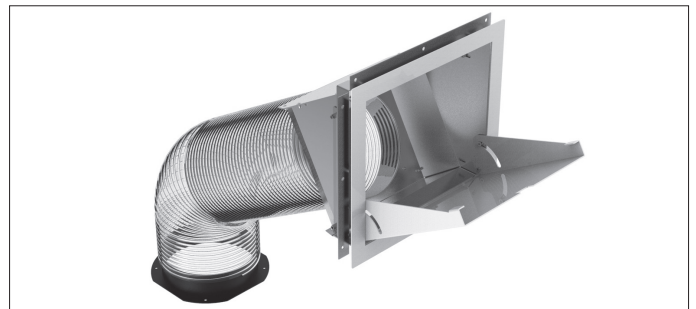
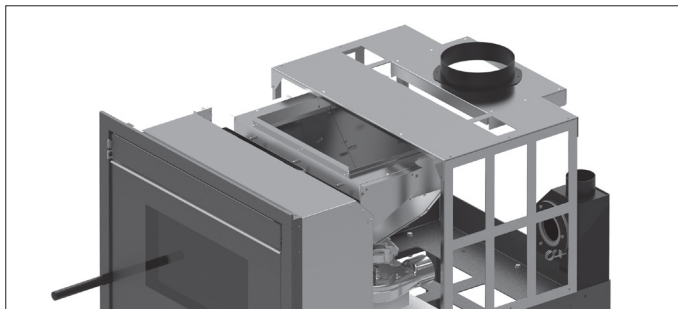

Now fit the side loading tank in the coating and connect the hose.

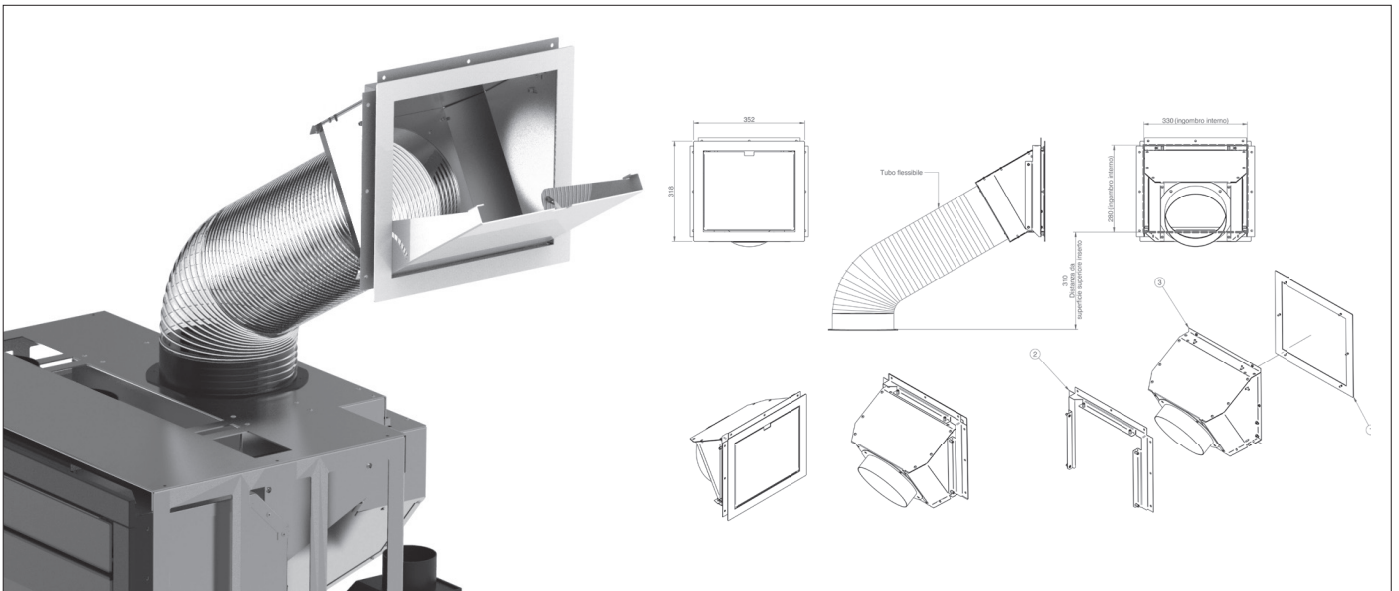

It is mandatory to have an opening in the brick / plasterboard coating to guarantee an adequate supply of air to the chimney (see page 8).

It is recommended to replicate the same opening made on the perimeter wall. Alternatively, the suction pipe (\varnothing 50 mm) can be connected to the outside of the home. If the suction tube is taken only outside of the brick cladding, it is mandatory to have an air intake on the perimeter wall of the house.



Remember that it is forbidden to inhale the combustion air from bedrooms, bathrooms, garages or deposits that could have explosive atmospheres.

Remote Control

The remote control (Fig. 3) used to adjust water temperature power and the on/off functions for the pellet Hydro Insert.

To start the Hydro Insert, press key \odot and the Hydro Insert will automatically enter the starting phase.

Press keys \uparrow + (1) and \downarrow - (2) to adjust temperature, and use keys \uparrow + (6) and \downarrow - (5) to adjust operating power.

To turn off the Hydro Insert, hold down key \odot .

To replace the 3 volt battery located on the back of the remote control, pull the centre of the cover and the lever on the side of the same, replace the battery observing the correct polarity (Fig. 4)



Fig. 3



Fig. 4

In order to achieve the test report results, please load the performance parameters retained by the manufacturer and the qualified technician. They will use these parameters once verified that, during the installation, it is possible to reproduce the laboratory conditions.

Plumbing system connection



The connection of the Hydro Insert to the plumbing system must be made ONLY by specialized personnel who are capable of carrying out installation properly, in compliance with current standards in the country of installation. The manufacturer will not be held responsible for damage to persons or things in the event of failed operation if the aforementioned warning is not complied with. anti-condensation valve must be installed in the return flow. It is mandatory to install an anti-condensate valve on the return of the system, set at 60 ° C. The valve isn't a standard Hydro Insert component and it isn't delivered with the Hydro Insert.

Closed vessel system

This product has been designed and built to work with closed vessel systems. In general, the closed vessel system has the following expansion **as the expansion vessel pre-loaded**. In addition to the expansion device, the closed vessel system must be provided in accordance with current Italian UNI 10412-2 (2009) by:

- safety valve
- thermostat control of the circulator
- device alarm sounds
- temperature Indicator
- pressure indicator
- audio alarm
- automatic adjustment
- safety thermostat with manual reset
- circulation system



Connection diagram for Hydro Insert

The pressure relief valve (C) must always be connected to a water drain pipe. The tube must be capable of withstanding high temperature and pressure.

Directions for use

If the installation of the Hydro Insert provides interaction with another existing system complete with a heater (gas Hydro Insert, gas Hydro Insert, oil Hydro Insert, etc..) consult qualified personnel who can then answer the compliance of the system, as envisaged by the law in force.

Flushing the system

In accordance with the UNI-CTI 8065 is strongly recommended to wash the entire system before connecting it in order to get rid of residues and deposits.

After flushing the system to protect it against corrosion and deposits, it is recommended the use of inhibitors. Upstream from the Hydro Insert, always install shutters so as to disconnect it from the plumbing system should it be necessary to move it, or when it requires routine and/or special maintenance. Connect the Hydro Insert using hoses so that the Hydro Insert is not too strictly connected to the system, and to allow slight movement.

These are as helpful as the supply and return piping system if the heating system is on a higher floor than the Hydro Insert.

The exhaust pipe pressure is connected temporarily to a carafe or a funnel to avoid, in case of overpressure, that the water gush bathrooms and the structure and the floor.

Filling the Hydro Insert funding of sanitary kit

Once all the water connections, proceed to check pressure seal by filling the Hydro Insert. During this operation, any air in the system is released from the **automatic vent valve**.

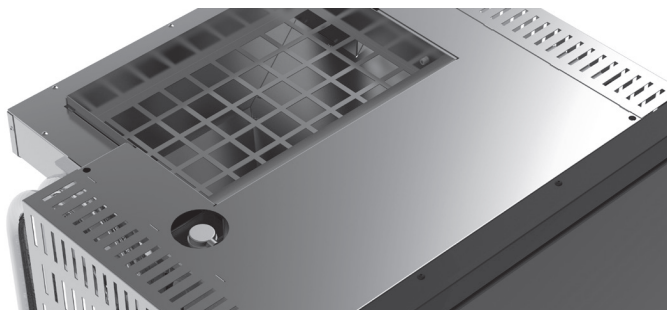

The filling pressure of the system **WHEN COLD** must be **1 bar**.

During operation, if the system pressure drops (due to evaporation of dissolved gases in the water) to values lower than the minimum indicated above, the user must use the filling tap to bring the pressure back up to its normal pressure.

For proper operation of the Hydro Insert **when hot**, the pressure in the Hydro Insert must be **1,5 bar**.

Replenishment of the System

The replenishment has to be slowly carried out in order to let the air bubbles flow out through the right outlets that are placed on the heating system. In heating systems with a closed circuit the loading cold pressure of the system and the inflation pressure of the expanding vase must correspond.

During the heating-season the user must regularly check the circulating water level in the expansion vase.

The content of water in the system of recirculation must be stable hold. Experiences show that the user must regularly check the water level every 14 days in order to maintain a stable water content. The replenishment process must be carried out in case of necessity of more water when the Hydro Insert has cooled down. These preventive measures aim to prevent the insurgence of thermic stress of the steel body of the Hydro Insert.



You must not mix water of the heating system with antifreeze or anticorrosion substances in wrong concentrations. This could ruin the seals and provoke the insurgence of noises while operating. The producer refuses any responsibility for damages towards persons, animals or things if this warning will not be respected.

The loading valve is required and must be provided in the hydraulic system.

This operation must be carried out with caution following these steps:

- open the vent's valve of the radiator ,of the Hydro Insert and the system;
- gradually open the filling tap of the system checking that the automatic vent's valves, placed on the system, are regularly working;
- close the vent's valves of the radiators as soon as the air flows out;
- check through the pressure gauge placed in the system that the pressure is reaching 1 bar (this is required only for systems with closed vase, you have to look for local rules that allow it)
- close the filling tap of the system and then let the air flow out again through the vent's valve of the radiator;

Water Characteristics

The characteristics of the water used to fill the system are very important to prevent the build-up of mineral salts and the formation of incrustations along the pipes, in the Hydro Insert and in the heat exchangers.

Therefore, please get your plumber's advice concerning:

- Hardness of water circulating in the system, to prevent problems of incrustation and limescale, especially in the domestic water heat exchanger (>15° French).
- Installation of a water softener (if water hardness > 15° French).
- Filling the system with treated water (demineralised).

If you have very extensive system, with a large amount of water, or which require frequent refilling, it is recommended the installation of water softening system. It should be noted that the encrustations drastically reduce performance because of their low thermal conductivity.

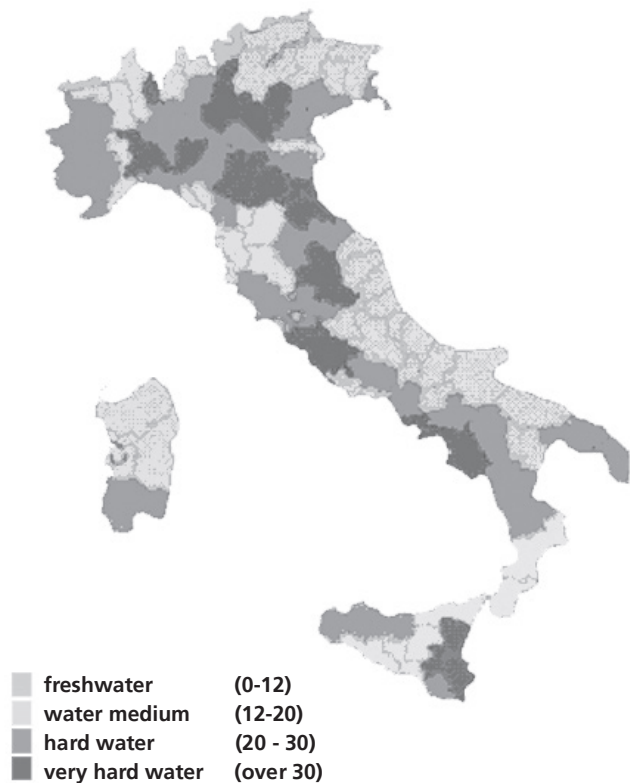

Pellet

The pellets are cylinders of compressed wood, produced from sawdust and wood processing (chips and sawdust), generally produced by sawmills and carpenters. The binding capacity of the lignin contained in wood, allows to obtain a compact product without adding additives and foreign chemicals to the wood, is therefore obtained a natural fuel with high yield.

The use of expired pellets or any other unsuitable material can damage parts of the Hydro Insert and impair proper operation: this can lead to the termination of the guarantee, and its producer responsibility.

For our products use pellets diameter 6 mm, length 30 mm and a maximum of 8% and A1 certified according to the UNI EN ISO 17225-2 standard. Keep the pellets away from heat sources and not in humid environments or with explosive atmosphere.



Configuration of the hydraulic diagram of the Hydro Insert

BY A SPECIALIZED TECHNICIAN

Before starting the Hydro Insert, it is necessary to configure the hydraulic scheme on which we want to work. The Hydro Insert is set up to receive the clean contact of an external thermostat (open / closed, the thermostat must not give tension to the back. If the thermostat carries voltage to the board causing faults, the warranty is void), two temperature probes and a motorized valve. All these components can be connected via the terminal board on the back of the Hydro Insert.

Electrical diagram of the control unit

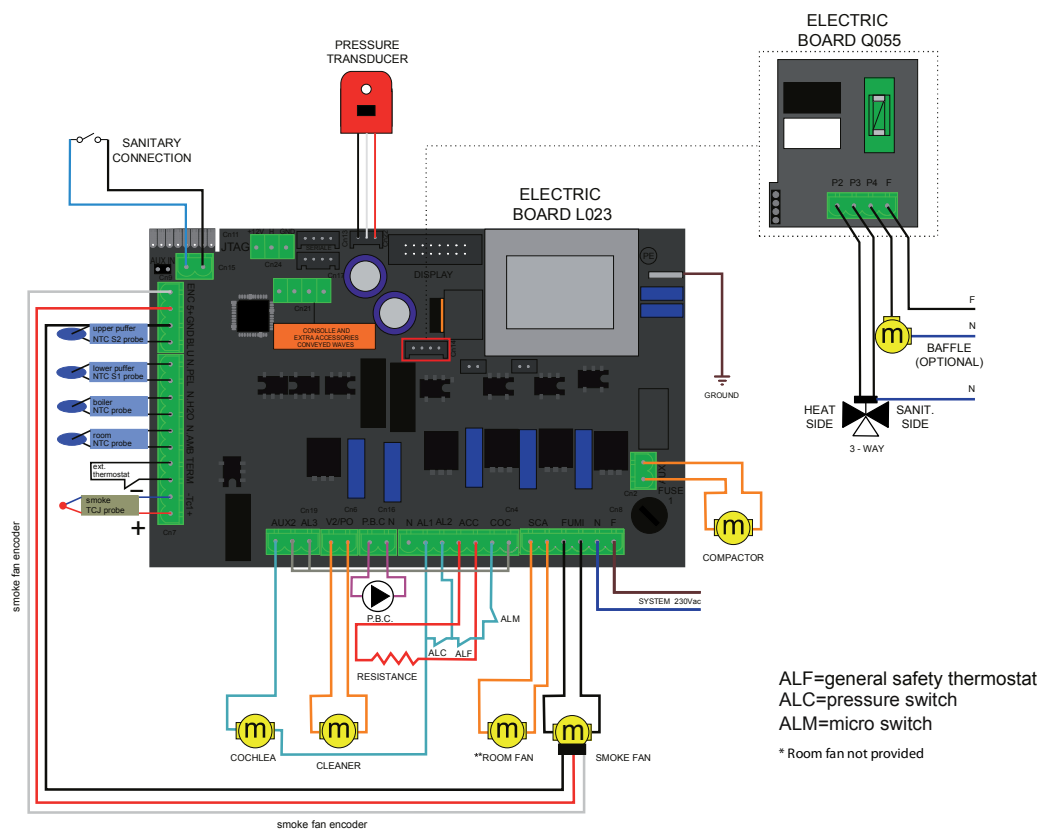

By a specialized technician:

To configure the hydraulic diagram, press the SET key and then 🔥 scroll to the "Technical settings" menu with the power key. Press the SET key again to enter the menu and enter the access key in possession of only the technician authorized by the manufacturer. Confirm the password using the set key and the key ⏴ of the power go to menu 3 "hydraulic scheme". Confirm with the SET key and use the 🔥 and 🔻 keys to select the required hydraulic scheme number.

For end user:

It is possible to change the Hydro Insert operating principle according to the season by choosing between summer and winter. To select the season press SET, the season selection will appear on the display. Then press the set key again and select the season with keys 1 and 2. Once selected, press the ON / OFF key to exit.

The choice of season changes the Hydro Insert operation, see next chapter.

Following the principles of operation of the various hydraulic diagrams.

Important considerations:

- healthcare will always have priority
- There are three types of stand-by:

Type 01: the ambient temperature detected by the probe on the board has reached the SET AIR set

Type 02: the water temperature in the Hydro Insert has reached the SET H2O set



Type 03: the external thermostat has detected that the desired temperature has been reached and therefore the contact is open.

In this specific case the Hydro Insert behaves as follows:

If the thermostat carries voltage to the card causing faults, the warranty will expire.

To configure the thermostat, simply remove the jumper on the THERM terminal (see the tab on page 16) and connect our room thermostat, OPERATION BY A SPECIALIZED TECHNICIAN.

How to select the type of Stand-by (OPERATION BY A SPECIALIZED TECHNICIAN):



Press the SET button; press button  to go to menu 09. Press the SET button again. Enter the access key and confirm it by pressing the SET key again. Press the  key to go to menu 9-5.

The display will show the different stand-by modes mentioned above, choose the mode using the  and  keys.

NOTE: The hydraulic scheme 00 is set by default, the WINTER season with stand-by mode 02.

When the Hydro Insert is switched off manually or by programming, automatic ignitions exit from a stand-by state will not be possible.

How to enable or disable the stand-by mode:

Press the SET button. With the , key, go to menu 05 and confirm with the SET key. Use key  to select whether to enable (ON) or disable (OFF) the Hydro Insert stand-by function.

Press the ON / OFF button to exit .

Let's see specifically the behavior of the Hydro Insert according to the hydraulic scheme, the presence and the stand-by mode and the chosen season

Scheme 00: hydro insert connected to the heating circuit and to a sanitary kit equipped with a flow switch installed from the producer only if specified when ordered. Defeated scheme, the absence of the sanitary kit does not cause problems to the functioning of the hydro insert.

The scheme is indicative and wants to demonstrate only the components that can be managed by the hydro insert. Any relay pumps must be controlled separately from the hydro insert.

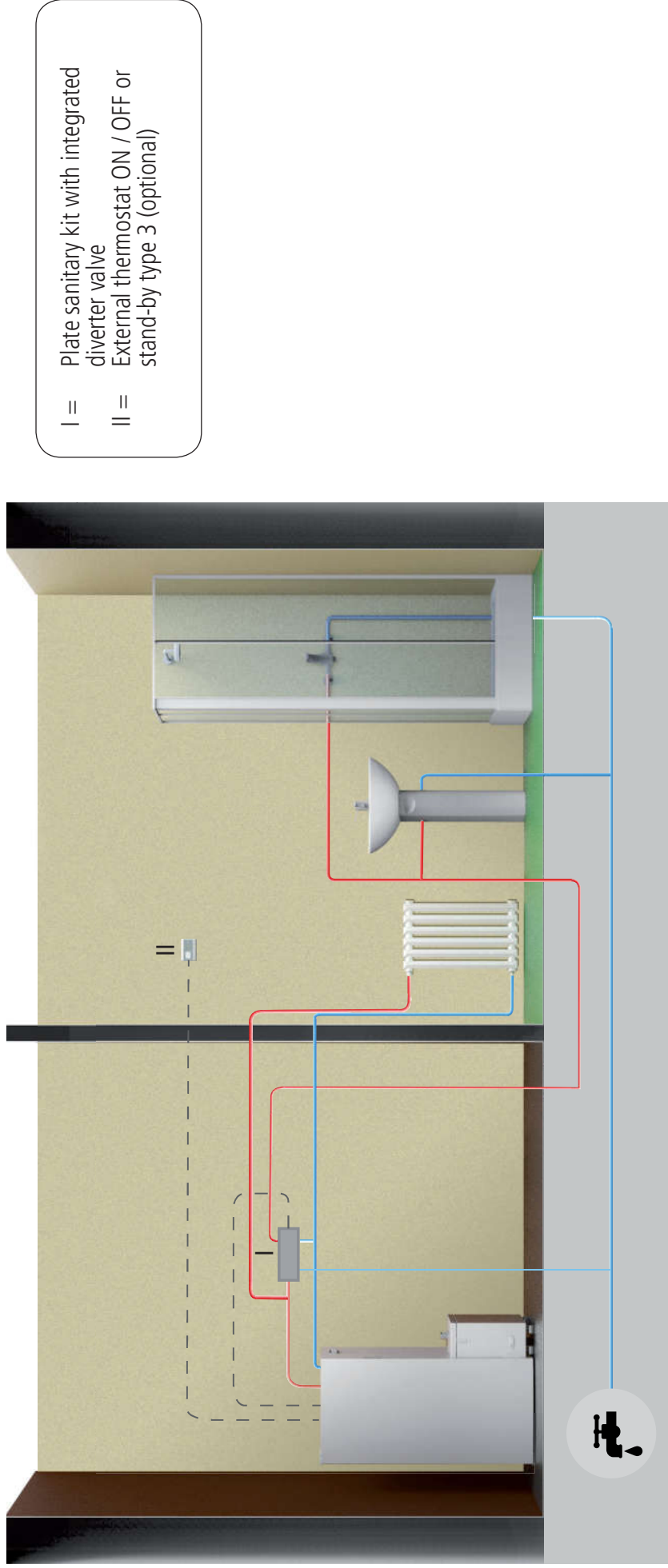

- a)** To set the water temperature in the hydro insert, press the . Increase or decrease degrees with the keys e .
- b)** To set the desired temperature in the room (using the probe on the board) press the key. Increase or decrease degrees with the and keys.
- c)** To set the work power, press the key and adjust it with the e .

Reaction from the stand-by state is when a heat increase is required to return to a chosen stand-by condition (when it is set to ON) or when there is a health risk.

Hydraulic scheme		Stand-by	Stand-by type	Season	hydro insert circulator status	hydro insert status
HEATING + SANITARY	SANITARY DOES NOT CALL	OFF	01 (AMB.)	WINTER	ON IF H ₂ O > PR. 25	MODULE IF PROBE H ₂ O > SET H ₂ O (a) OR IF AMB PROBE. > AIR SET (b)
HEATING + SANITARY	HEALTH CALL	OFF	01 (AMB.)	WINTER	ON IF H ₂ O > PR. 25	MODULE IF PROBE H ₂ O > 80 ° C
HEATING + SANITARY	SANITARY DOES NOT CALL	ON	01 (AMB.)	WINTER	ON IF H ₂ O > PR. 25	STAND-BY IF AMB PROBE > SET AMB. (B); MODULE SE H ₂ O > SET H ₂ O;
HEATING + SANITARY	HEALTH CALL	ON	01 (AMB.)	WINTER	ON IF H ₂ O > PR. 25	MODULE IF PROBE H ₂ O > 80 ° C
HEATING + SANITARY	SANITARY DOES NOT CALL	OFF	02 (H ₂ O)	WINTER	ON IF H ₂ O > PR. 25	MODULE IF PROBE H ₂ O > SET H ₂ O (a)
HEATING + SANITARY	HEALTH CALL	OFF	02 (H ₂ O)	WINTER	ON IF H ₂ O > PR. 25	MODULE IF PROBE H ₂ O > 80 ° C
HEATING + SANITARY	SANITARY DOES NOT CALL	ON	02 (H ₂ O)	WINTER	ON IF H ₂ O > PR. 25	STAND-BY IF PROBE H ₂ O > SET H ₂ O (a)
HEATING + SANITARY	HEALTH CALL	ON	02 (H ₂ O)	WINTER	ON IF H ₂ O > PR. 25	MODULE IF PROBE H ₂ O > 80 ° C
HEATING + SANITARY	SANITARY DOES NOT CALL	OFF	03 (TERM. ES.)	WINTER	ON IF H ₂ O > PR. 25	MODULE SE TERM. ES. SATISFIED OR IF H ₂ O PROBE > SET H ₂ O (a)
HEATING + SANITARY	HEALTH CALL	OFF	03 (TERM. ES.)	WINTER	ON IF H ₂ O > P PR. 25	MODULE SE PROBE H ₂ O > 80 ° C
HEATING + SANITARY	SANITARY DOES NOT CALL	ON	03 (TERM. ES.)	WINTER	ON IF H ₂ O > PR. 25	STAND-BY TERM. ES. SATISFIED; MODULE SE H ₂ O > SET H ₂ O; (B)
HEATING + SANITARY	HEALTH CALL	ON	03 (TERM. ES.)	WINTER	ON IF H ₂ O > PR. 25	MODULE IF PROBE H ₂ O > 80 ° C
HEATING + SANITARY	SANITARY DOES NOT CALL	OFF	ONLY 2 (H ₂ O)	SUMMER	ON IF H ₂ O > PR. 25	STAND-BY IF H ₂ O PROBE > SET FORWARD STAND-BY IN (a)
HEATING + SANITARY	HEALTH CALL	OFF	ONLY 2 (H ₂ O)	SUMMER	ON IF H ₂ O > PR. 25	MODULE SE PROBE H ₂ O > 80 ° C
HEATING + SANITARY	SANITARY DOES NOT CALL	ON	ONLY 2 (H ₂ O)	SUMMER	ON IF H ₂ O > PR. 25	STAND-BY IF PROBE H ₂ O > SET H ₂ O (a)
HEATING + SANITARY	HEALTH CALL	ON	ONLY 2 (H ₂ O)	SUMMER	ON IF H ₂ O > PR. 25	MODULE IF PROBE H ₂ O > 80 ° C

NB: By setting the “Summer” command, the hydro insert will go into standby and will only switch back on if there is a sanitary water call.

Scheme 01: the hydro insert is connected to a domestic hot water tank and to the heating circuit.

During the "WINTER" mode the hydro insert is switched off when the contact (thermostat) below is satisfied. The hydro insert is switched on when the contact (thermostat) detects a temperature below SET ACS - ΔT (ΔT can be set by technical parameters).

By setting the "SUMMER" mode the temperature is considered always satisfied.

The scheme is indicative and wants to demonstrate only the components that can be managed by the hydro insert. Any relay pumps must be controlled separately from the hydro insert.

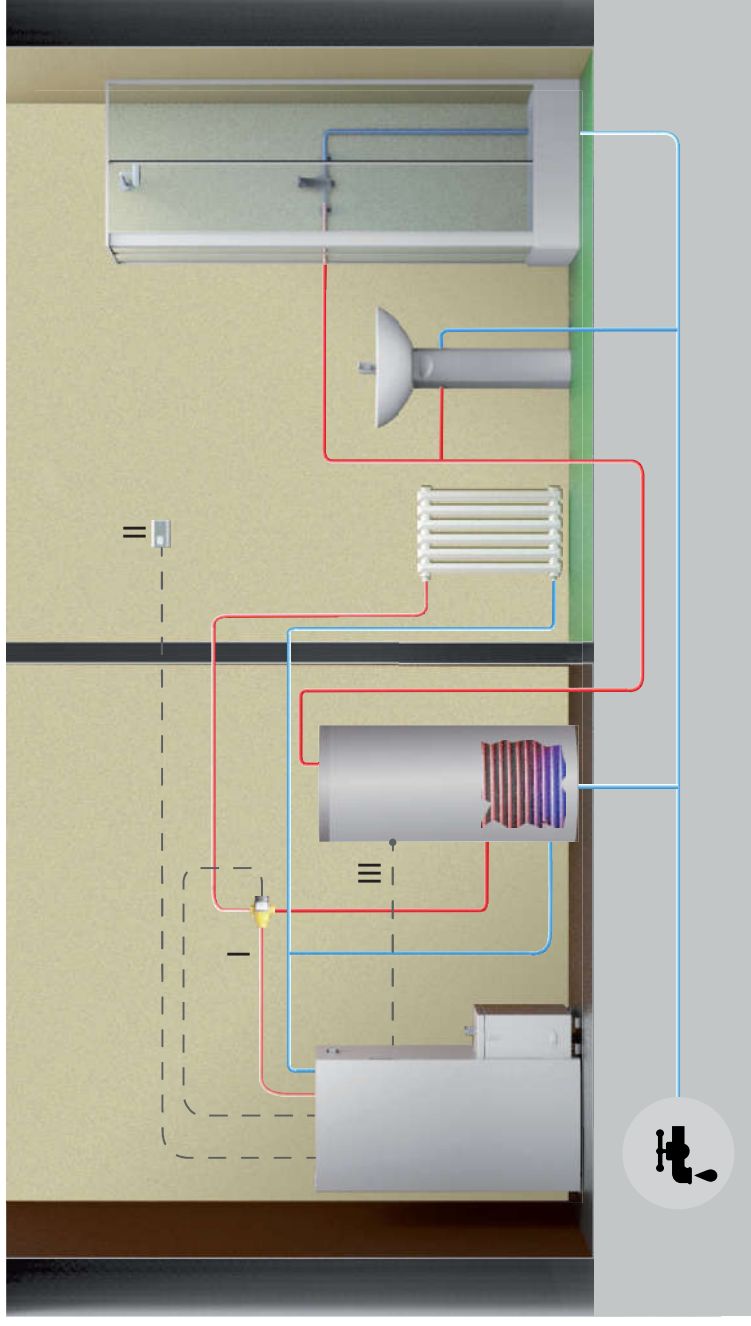

I = Valve motorization

II = External thermostat ON / OFF or stand-by type 3 (optional)

III = ON / OFF thermostat on ACS tank

- a) To set the water temperature in the hydro insert, press the key. Increase or decrease degrees with keys and .
- b) To set the desired temperature in the room (using the probe on the board) press the key. Increase or decrease degrees with keys and .
- c) To set the work power press the key and adjust it with the and keys.

The rinsing from the stand-by state occurs automatically when a heat increase is required to return to satisfy the chosen stand-by condition (when this is set to ON) or when there is a health risk.

Hydraulic scheme		Stand-by	Stand-by state	Season	circulator heater condition	State heating hydro insert
HEATING + ACS IN CONTACT	SANITARY DOES NOT CALL	OFF	01 (AMB.)	WINTER	ON IF H ₂ O > PR. 25	MODULE IF PROBE H ₂ O > SET H ₂ O (a); IF AMB PROBE > AIR SET (b)
HEATING + ACS IN CONTACT	SANITARY IN CALL	OFF	01 (AMB.)	WINTER	ON IF H ₂ O > PR. 25 e H ₂ O > ACS	MODULE IF PROBE H ₂ O > 80 ° C
HEATING + ACS IN CONTACT	SANITARY DOES NOT CALL	ON	01 (AMB.)	WINTER	ON IF H ₂ O > PR. 25	MODULE SE H ₂ O > SET H ₂ O; (a) STAND- BY IF AMB PROBE. > SET AMB.; (B)
HEATING + ACS IN CONTACT	SANITARY IN CALL	ON	01 (AMB.)	WINTER	ON IF H ₂ O > PR. 25 e H ₂ O > ACS	MODULE IF PROBE H ₂ O > 80 ° C
HEATING + ACS IN CONTACT	SANITARY DOES NOT CALL	OFF	02 (H ₂ O)	WINTER	ON IF H ₂ O > PR. 25	MODULE IF PROBE H ₂ O > SET H ₂ O (a)
HEATING + ACS IN CONTACT	SANITARY IN CALL	OFF	02 (H ₂ O)	WINTER	ON IF H ₂ O > PR. 25 e H ₂ O > ACS	MODULE IF PROBE H ₂ O > 80°C
HEATING + ACS IN CONTACT	SANITARY DOES NOT CALL	ON	02 (H ₂ O)	WINTER	ON IF H ₂ O > PR. 25	STAND-BY IF PROBE H ₂ O > SET H ₂ O (a)
HEATING + ACS IN CONTACT	SANITARY IN CALL	ON	02 (H ₂ O)	WINTER	ON IF H ₂ O > PR. 25 e H ₂ O > ACS	MODULE IF PROBE H ₂ O > 80°C
HEATING + ACS IN CONTACT	SANITARY DOES NOT CALL	OFF	03 (TERM. ES.)	WINTER	ON IF H ₂ O > PR. 25	MODULE IF EXTERNAL THERMOSTAT SATISFIED OR IF PROBE H ₂ O > SET H ₂ O (a)
HEATING + ACS IN CONTACT	SANITARY IN CALL	OFF	03 (TERM. ES.)	WINTER	ON IF H ₂ O > PR. 25 e H ₂ O > ACS	MODULE IF PROBE H ₂ O > 80°C
HEATING + ACS IN CONTACT	SANITARY DOES NOT CALL	ON	03 (TERM. ES.)	WINTER	ON IF H ₂ O > PR. 25	STAND-BY EXTERNAL THERMOSTAT SATISFIED; MODULE IF H ₂ O > SET H ₂ O; (to)
HEATING + ACS IN CONTACT	SANITARY IN CALL	ON	03 (TERM. ES.)	WINTER	ON IF H ₂ O > PR. 25 e H ₂ O > ACS	MODULE IF PROBE H ₂ O > 80°C
HEATING + ACS IN CONTACT	SANITARY DOES NOT CALL	OFF/ON	01/02/03	SUMMER	ON IF H ₂ O > PR. 25	STAND-BY
HEATING + ACS IN CONTACT	SANITARY IN CALL	OFF/ON	01/02/03	SUMMER	ON IF H ₂ O > PR. 25 e H ₂ O > ACS	MODULE IF PROBE H ₂ O > 80°C

Scheme 02 : the hydro insert is connected to a technical water puffer.

The hydro insert is switched off when the lower contact (thermostat) is satisfied.

The hydro insert is switched on when the upper contact (thermostat) is not satisfied.

The heating water will then be taken from this puffer by means of the pumps and the relays are not controlled by the hydro insert control unit.

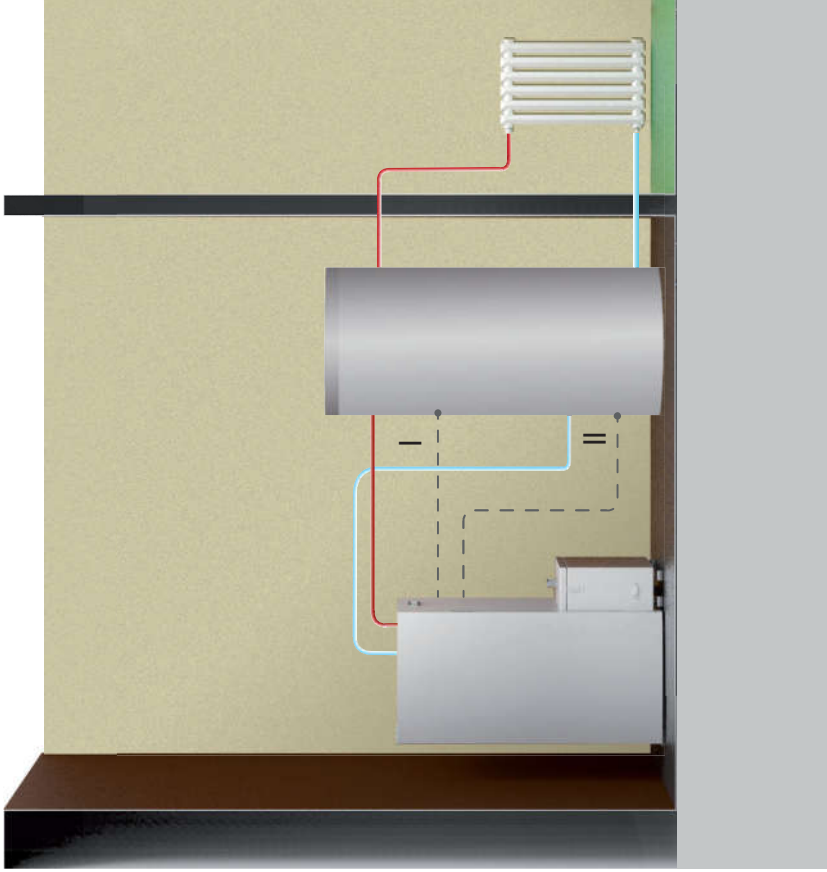

The scheme is indicative and wants to demonstrate only the components that can be managed by the hydro insert. Any relay pumps must be controlled separately from the hydro insert.

I = ON / OFF higher thermostat
on Technical water Puffer (3)
II = ON / OFF lower thermostat
on Technical water Puffer (2)

- a) To set the hydro insert water temperature, press the . Increase or decrease the degrees with the  and .
- b) To set the desired temperature in the room (using the probe on the board) press the  key. Increase or decrease degrees with the  and  keys.

The working power is automatically set from the machine.

The rinsing from the stand-by state occurs automatically when a heat increase is required to return to satisfy the chosen stand-by condition (when this is set to ON) or when there is a risk of hot water inside the puffer.

Hydraulic scheme		Stand-by	Stand-by state	Season	Circulator heater condition	State heating hydro insert
CONTACT PUFFER	LOW AND HIGH THERMOSTAT DO NOT CALL	OFF	01/02/03	WINTER / SUMMER	ON IF H ₂ O > PR 25	MODULE AND IF H ₂ O PROBE > 80 ° STAND-BY FORCE
CONTACT PUFFER	LOW THERMOSTAT CALLS AND HIGH DOES NOT CALL	OFF	01/02/03	WINTER / SUMMER	ON IF H ₂ O > PR 25	WORK AND IF H ₂ O PROBE > 80 ° MODULE
CONTACT PUFFER	LOW AND HIGH CALL THERMOSTAT	OFF	01/02/03	WINTER / SUMMER	ON IF H ₂ O > PR 25	WORK AND IF H ₂ O PROBE > 80 ° MODULE
CONTACT PUFFER	LOW THERMOSTAT DOES NOT CALL AND HIGH CALL	OFF	01/02/03	WINTER / SUMMER	ON IF H ₂ O > PR 25	WORK AND IF H ₂ O PROBE > 80 ° MODULE
CONTACT PUFFER	LOW AND HIGH THERMOSTAT DO NOT CALL	ON	01/02/03	WINTER / SUMMER	OFF	STAND-BY
CONTACT PUFFER	LOW THERMOSTAT CALLS AND HIGH DOES NOT CALL	ON	01/02/03	WINTER / SUMMER	ON IF H ₂ O > PR 25	WORK AND IF H ₂ O PROBE > 80 ° MODULE
CONTACT PUFFER	LOW AND HIGH CALL THERMOSTAT	ON	01/02/03	WINTER / SUMMER	ON IF H ₂ O > PR 25	WORK AND IF H ₂ O PROBE > 80 ° MODULE
CONTACT PUFFER	LOW THERMOSTAT DOES NOT CALL AND HIGH CALL	ON	01/02/03	WINTER / SUMMER	ON IF H ₂ O > PR 25	WORK AND IF H ₂ O PROBE > 80 ° MODULE

Scheme 03: the hydro insert is connected to a domestic hot water tank and to the heating circuit.

During the “WINTER” mode the hydro insert is switched off when the probe is satisfied. The hydro insert is switched on when the probe detects a lower temperature to SET DHW - ΔT (ΔT settable by technical parameters). By setting the “SUMMER” mode the temperature is considered always satisfied.

The scheme is indicative and wants to demonstrate only the components that can be managed by the hydro insert. Any relay pumps must be controlled separately from the hydro insert.

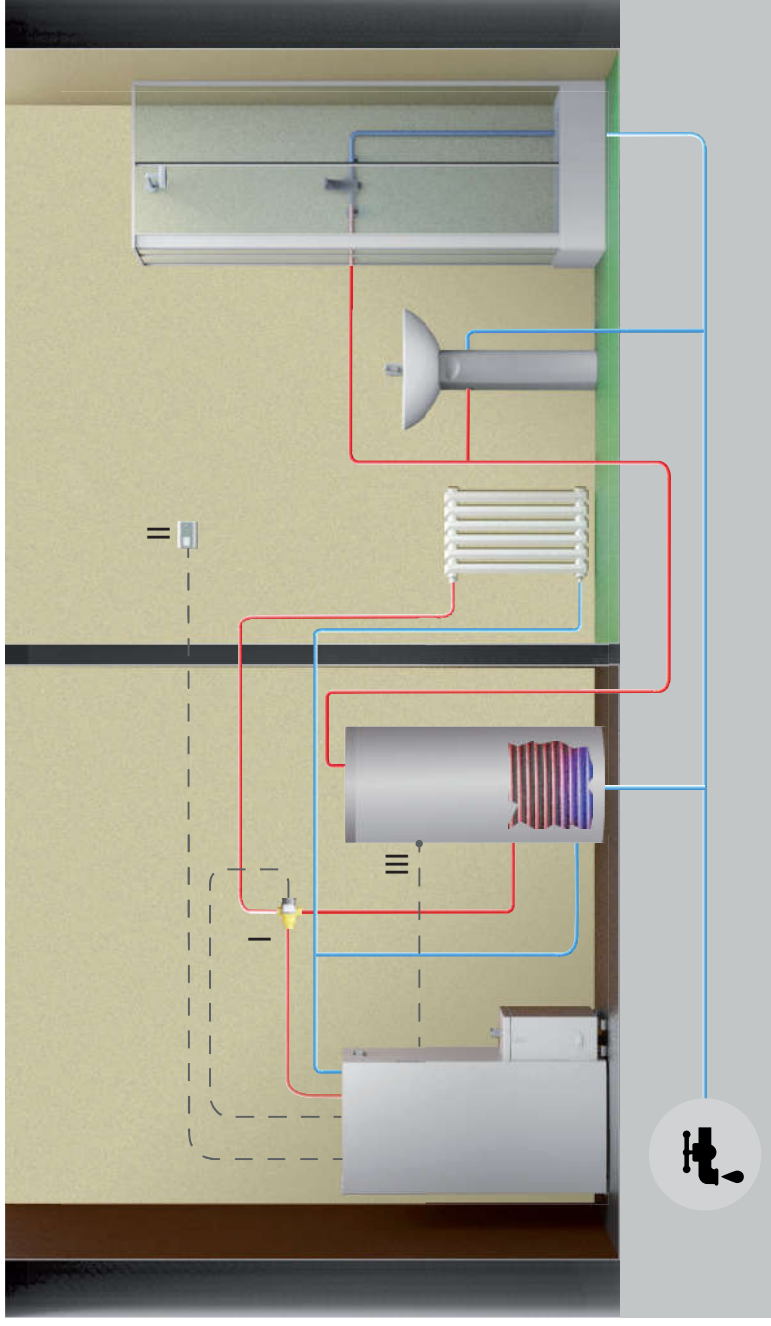

I = Valve motorization

II = External thermostat ON / OFF or stand-by type 3 (optional)

III = NTC 10K probe on DHW tank

- a) To set the water temperature in the hydro insert press the key. Increase or decrease the degrees with the and keys.
- b) To set the desired temperature in the room (using the probe on the board) press the key. Increase or decrease degrees with the and keys.
- c) To set the work power, press the key and adjust it with the and keys.
- d) To adjust the temperature inside the DHW tank, press the button . Increase or decrease the desired degrees with the and .

Sanitary water will always have priority on the heating.

The rinsing from the stand-by state occurs automatically when a heat increase is required to return to satisfy the chosen stand-by condition (when this is set to ON) or when there is a risk of hot water inside the DHW tank.

Hydraulic scheme	Stand-by	Stand-by state	Season	Circulator heater condition	State heating hydro insert
HEATING + DHW WITH PROBE	OFF	01 (AMB.)	WINTER	ON IF H ₂ O > PR 25	RATED HEAT INPUT IF H ₂ O PROBE > SET H ₂ O (a) OR IF AMB PROBE > SET (b)
HEATING + DHW WITH PROBE	OFF	01 (AMB.)	WINTER	ON IF H ₂ O > SON ACS + 3° AND IF H ₂ O > PR 25	OPERATION AND RATED HEAT INPUT IF PROBE H ₂ O > SET DHW + 10 (d)
HEATING + DHW WITH PROBE	ON	01 (AMB.)	WINTER	ON IF H ₂ O > PR 25	STAND-BY IF AMB PROBE > AIR SET (b)
HEATING + DHW WITH PROBE	ON	01 (AMB.)	WINTER	ON IF H ₂ O > ACS + 3° AND IF H ₂ O > PR 25	OPERATION AND RATED HEAT INPUT IF PROBE H ₂ O > SET ACS + 10 (d)
HEATING + DHW WITH PROBE	OFF	02 (H ₂ O)	WINTER	ON IF H ₂ O > PR 25	RATED HEAT INPUT IF PROBE H ₂ O > SET H ₂ O (a)
HEATING + DHW WITH PROBE	OFF	02 (H ₂ O)	WINTER	ON IF H ₂ O > ACS + 3° AND IF H ₂ O > PR 25	OPERATION AND RATED HEAT INPUT IF PROBE H ₂ O > SET ACS + 10 (d)
HEATING + DHW WITH PROBE	ON	02 (H ₂ O)	WINTER	ON IF H ₂ O > PR 25	STAND-BY IF PROBE H ₂ O > SET H ₂ O (a)
HEATING + DHW WITH PROBE	ON	02 (H ₂ O)	WINTER	ON IF H ₂ O > ACS + 3° AND IF H ₂ O > PR 25	RATED HEAT INPUT IF PROBE H ₂ O > SET ACS + 10 (d)
HEATING + DHW WITH PROBE	OFF	03 (TERM. ES.)	WINTER	ON IF H ₂ O > PR 25	RATED HEAT INPUT IF THERMOSTAT EXTERNAL SATISFIED
HEATING + DHW WITH PROBE	OFF	03 (TERM. ES.)	WINTER	ON IF H ₂ O > ACS + 3° AND IF H ₂ O > PR 25	OPERATION AND RATED HEAT INPUT IF PROBE H ₂ O > SET ACS + 10 (d)
HEATING + DHW WITH PROBE	ON	03 (TERM. ES.)	WINTER	ON IF H ₂ O > PR 25	STAND-BY THERMOSTAT EXTERNAL SATISFIED; RATED HEAT INPUT IF H ₂ O > SET H ₂ O (a);
HEATING + DHW WITH PROBE	ON	03 (TERM. ES.)	WINTER	ON IF H ₂ O > ACS + 3° AND IF H ₂ O > PR 25	OPERATION AND RATED HEAT INPUT IF PROBE H ₂ O > SET ACS + 10 (d)
HEATING + DHW WITH PROBE	OFF/ON	ONLY 2 (H ₂ O)	SUMMER	ON IF H ₂ O > ACS + 3° AND IF H ₂ O > PR 25	STAND-BY IF DHW PROBE > SET ACS + 1 AND FORCE ST-BY IN ON (d)
HEATING + DHW WITH PROBE	OFF/ON	ONLY 2 (H ₂ O)	SUMMER	ON IF H ₂ O > ACS + 3° AND IF H ₂ O > PR 25	OPERATION AND RATED HEAT INPUT IF PROBE H ₂ O > SET ACS + 10 (d)

Once the “Stand-by” condition is satisfied, before the shutdown, a time set by parameter must pass without a change of state.

Scheme 04 : the hydro insert is connected to a technical water puffer.

The hydro insert is turned off when the lower probe is satisfied.

The heating hydro insert is switched on when the upper probe is not satisfied.

The heating water will then be taken from this puffer by means of the pumps and the non-commanding relay from the hydro insert's control unit.

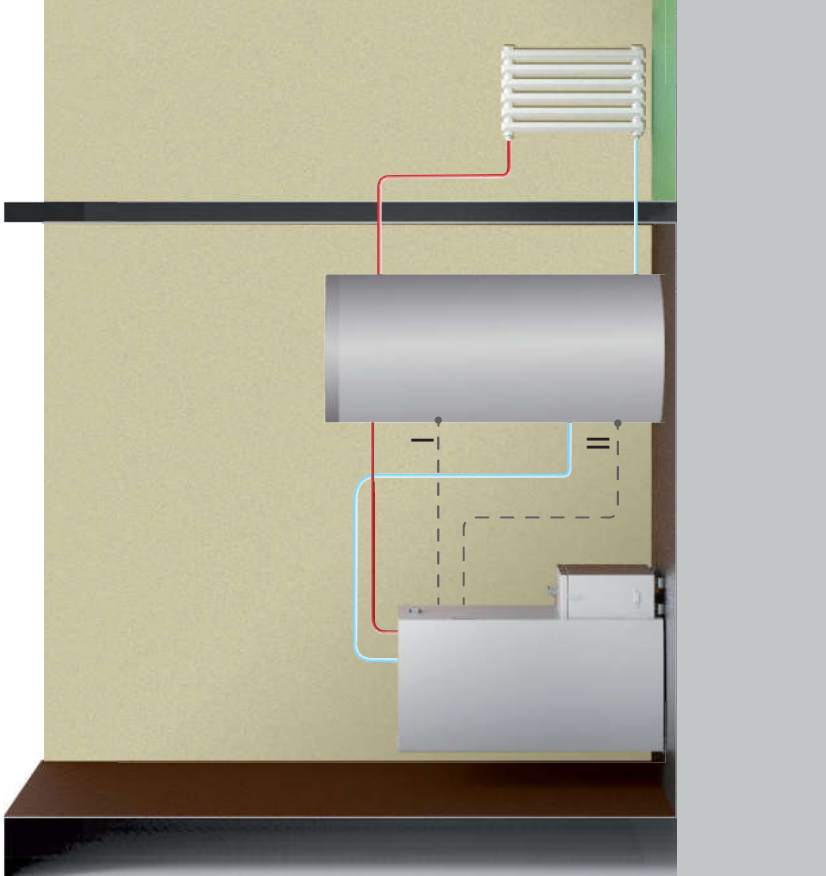

The scheme is indicative and wants to demonstrate only the components that can be managed by the hydro insert. Any relay pumps must be controlled separately from the hydro insert

- I = Upper probe NTC10K on technical water puffer
- II = Lower probe NTC10K on technical water puffer

- a) To set the temperature at the top of the puffer, press the  key. Use the  and  keys to select the desired degrees
- b) To set the temperature on the bottom of the puffer, press the  key and use the  e  and B keys to select the desired degrees

The working power is set automatically by the machine.

N.B. For correct operation the upper SET must be set at a lower temperature than the lower SET.

Hydraulic scheme	Stand-by	Stand-by state	Season	3 way	Circulator heater condition	State heating hydro insert
2-SIDE PUFFER (4)	OFF	01/02/03	WINTER / SUMMER	OFF	ON IF H ₂ O > PR 25 AND H ₂ O > S1 + 3°	RATED HEAT INPUT AND IF H ₂ O PROBE > 80 ° STAND-BY FORCE
2-SIDE PUFFER (4)	OFF	01/02/03	WINTER / SUMMER	ON	ON IF H ₂ O > S1 + 3° H ₂ O > PR 25	H ₂ O PROBE > 80 ° RATED HEAT INPUT
2-SIDE PUFFER (4)	ON	01/02/03	WINTER / SUMMER	OFF	OFF	STAND-BY
2-SIDE PUFFER (4)	ON	01/02/03	INVERNO/ ESTATE	ON	ON IF H ₂ O > S1 + 3° H ₂ O > PR 25	H ₂ O PROBE > 80 ° RATED HEAT INPUT

Stand-by is recommended to ON

S1: Upper Probe (I)

S2: Lower Probe (II)

It is possible that the circulator works despite the hydro insert is set on "OFF" or "STAND BY". This happens because the temperature of the water inside the hydro insert is higher than the temperature of the puffer's top.

Scheme 05 : the hydro insert is connected to a technical water puffer and to an ACS tank.

The hydro insert is switched off when all the probes are satisfied. The hydro insert is switched on when one of the probes is on call. The heating water will then be taken from this puffer by means of the pumps and the relays are not controlled by the hydro insert control unit.

The scheme is indicative and wants to demonstrate only the components that can be managed by the hydro insert. Any relay pumps must be controlled separately from the hydro insert.

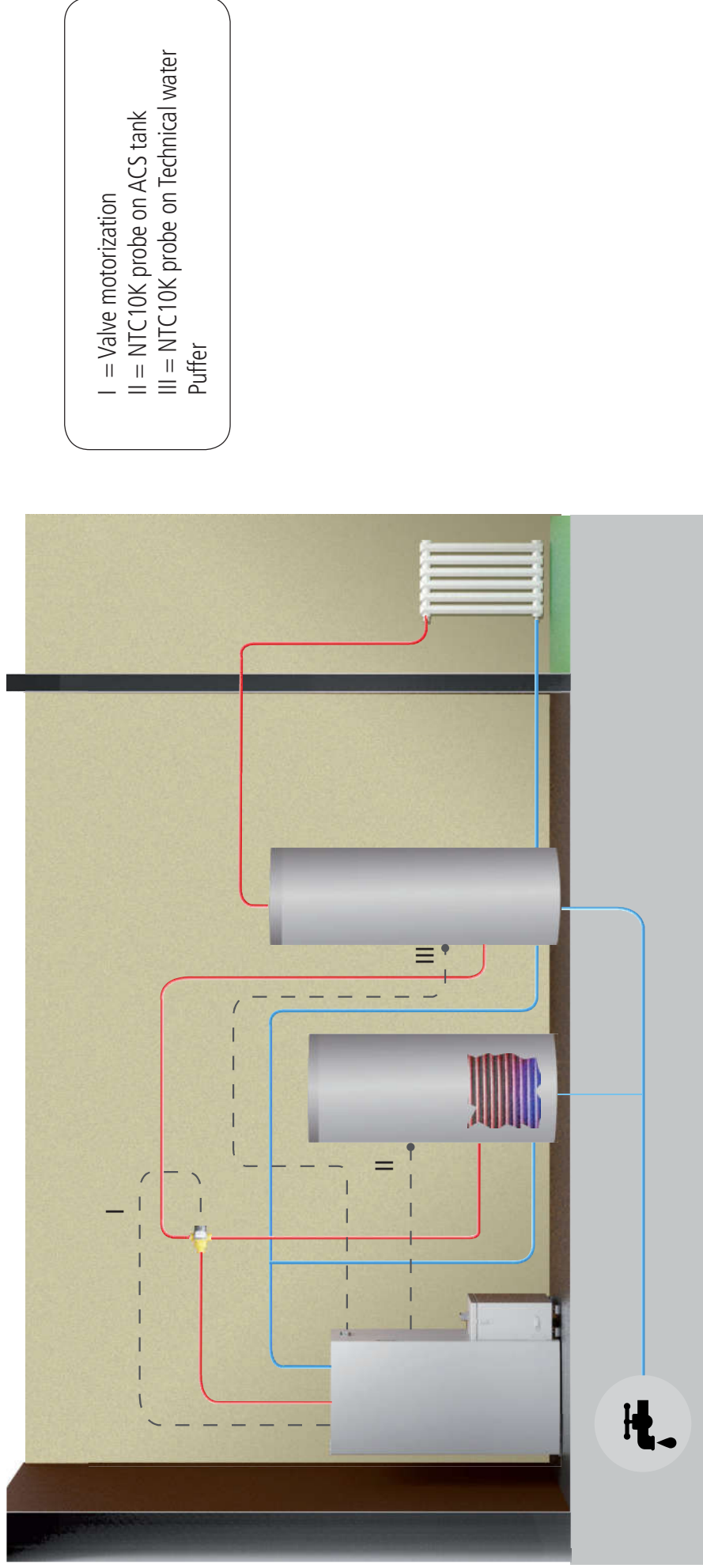

- a) To set the temperature in the DHW tank, press the key. Use the and keys to select the desired degrees
- b) To set the temperature in the technical water puffer, press the key and use the and keys to select the desired degrees
- c) To set the work power press the key and adjust it with the keys and

Sanitary water will always have priority on the heating.

Hydraulic scheme		Stand-by	Stand-by state	Season	Pump	State heating hydro insert
PUFFER + DHW TANK WITH PROBE	DHW PROBE < DHW SET AND PUFFER PROBE > SET PUFFER	OFF	01/02/03	WINTER	ON IF H ₂ O > DHW PROBE +3°	RATED HEAT INPUT AND IF H ₂ O PROBE > 80 ° STAND-BY FORCE
PUFFER + DHW TANK WITH PROBE	DHW PROBE < DHW SET AND PUFFER PROBE > SET PUFFER	ON	01/02/03	WINTER	ON IF H ₂ O > DHW PROBE +3° IF H ₂ O > PR 25	OPERATION AND RATED HEAT INPUT H ₂ O PROBE > 80 °
PUFFER + DHW TANK WITH PROBE	DHW PROBE > DHW SET AND PUFFER PROBE < SET PUFFER	ON	01/02/03	WINTER	ON IF H ₂ O > PUFFER +3° H ₂ O > PR 25	OPERATION AND RATED HEAT INPUT PROBE H ₂ O > 80 °
PUFFER + DHW TANK WITH PROBE	DHW PROBE > DHW SET AND PUFFER PROBE < SET PUFFER	OFF	01/02/03	WINTER	ON IF H ₂ O > PROBE PUFFER + 3° H ₂ O > PR 25	OPERATION AND RATED HEAT INPUT H ₂ O PROBE > 80 °
PUFFER + DHW TANK WITH PROBE	DHW PROBE > DHW SET AND PUFFER PROBE > SET PUFFER	OFF	01/02/03	WINTER	ON IF H ₂ O+5 > PROBE PUFFER	RATED HEAT INPUT
PUFFER + DHW TANK WITH PROBE	DHW PROBE > DHW SET AND PUFFER PROBE > SET PUFFER	ON	01/02/03	WINTER	ON IF H ₂ O > PROBE DHW AND IF H ₂ O > PR PUMP ON	STAND-BY
PUFFER +DHW TANK WITH PROBE	SONDA DHW > SET DHW	OFF/ON	SOLO 2 (H ₂ O)	SUMMER	ON IF H ₂ O > PROBE DHW +3° H ₂ O > PR 25	STAND-BY IF DHW PROBE > SET DHW + 1 AND FORCE ST-BY IN ON
PUFFER + DHW PROBE HYDRO INSERT	SONDA DHW < SET DHW	OFF/ON	SOLO 2 (H ₂ O)	SUMMER	ON IF H ₂ O > PROBE DHW +3° H ₂ O > PR 25	RATED HEAT INPUT IF H ₂ O PROBE > SET DHW +10

When the hydro insert is working and the H₂O's hydro insert = SET ACS +10° → pass in modulation

NB: Keeping the "SUMMER" command set, the technical water Puffer is always considered satisfied.

Ignition



Remove any components which might burn from the firebox and from the glass (various instructions and adhesive labels)

Charge pellet

Fuel is loaded from the upper part by opening a door. Pour the pellets in the hopper. When empty, this is easier if performed in two steps:

- Pour half of the contents of the bag into the hopper and wait for the fuel to settle on the bottom.
- Then pour in the rest.



Never remove the protection grille in the hopper. When filling, do not let the sack of pellets touch any hot surfaces.









The brazier should be cleaned before each starting.

Control Panel

Button  is used to switch the machine on/off and to exit programming.

Buttons  and  are used to adjust temperature, for displays and for the programming functions.

Buttons  and  are used to adjust heating power.

LED	SYMBOL	DESCRIPTION
1		The LED lights up when a program is active.
2		The LED lights up when the resistance is active.
3		The LED lights up when the loading of pellet is active.
4		The LED lights up when the smoke fan is active.
5		The LED lights up when the room fan is active. (where present)
6		The LED lights up when the circulator is active. (Boilers and thermostoves)
7		The LED lights up when there is a warning.

1. Temperature increase
2. Temperature decrease
3. Key SET
4. Pulsante on/off
5. Operating power decrease
6. Operating power increase

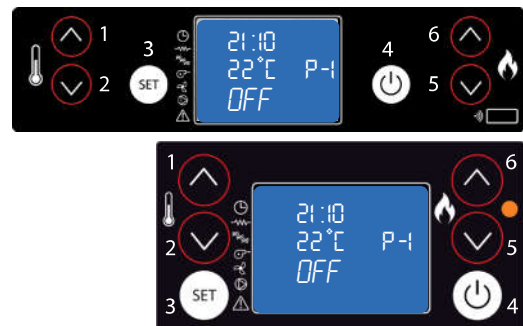

For our products use pellets diameter 6 mm, length 30 mm and a maximum of 6% and A1 certified according to the UNI EN ISO 17225-2 standard. Keep the pellets away from heat sources and not in humid environments or with explosive atmosphere.

Preliminary checks

Before switching on the machine, make sure that the pellet hopper is full, the combustion chamber is clean, the glass door is closed, the power supply plug is connected and the switch on the back is set to "1."

Information on the display



TURNED OFF

The machine is off.

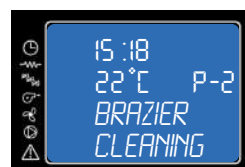

BRAZIER CLEANING

The machine is cleaning the basket. The smoke extractor runs at maximum speed and the pellet load is at minimum.



TURNED ON

The machine is in the first ignition phase. The glow plug and fume extractor are active.



OK STAND BY

All the requests have been satisfied and the machine is ready for the "STAND BY" mode.



LOAD PELLET

In this phase of the ignition process the machine starts loading the pellets into the brazier. The glow plug, the fume extractor and the cochlea engine are active.



HOLD REQUEST

The machine is in a "STAND BY" mode as everything has been satisfied and is waiting for an heating request to turn on.



FIRE PRESENT

In this phase of the ignition process the machine starts loading the pellets into the brazier. The fume extractor and the cochlea engine are active.



WAIT COOLING

The machine has to complete the cooling cycle before turning on again.



WORK

The machine is working, in this case at power 3. The detected room temperature is 21 ° C. During normal work, the fumes fan, the auger motor and the room fan are active.

Programming menu

Menu 02 SET CLOCK

To access the set clock option, press the "SET" button (3), with the button (5) scroll through the submenus until MENU 02 - SET CLOCK and with buttons 1 and 2 select the current day. Press the "SET" button (3) to confirm. Then use buttons 1 and 2 to set the time and press "SET" (3) to advance to the minutes setting by pressing buttons 1 and 2. By pressing set again it's possible to access various submenus in order to set the date, day, month, and year. To do so, repeat the steps indicated above, using buttons 1, 2, and 3. The following table briefly describes the structure of the menu, focusing only on those selections which are available to the user.

level 1	level 2	level 3	level 4	value
02 - set clock				
	01 - day			day of the week
	02 - hour			hour
	03 - minutes			minutes
	04 - day			day of the month
	05 - month			month
	06 - year			year

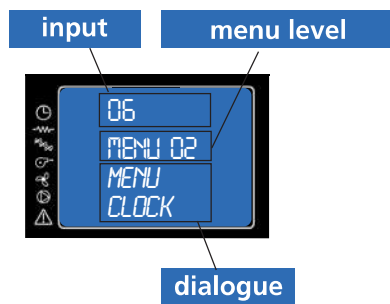

Set the current time and date. The device comes equipped with a lithium battery that allows the internal clock to operate autonomously for over 3-5 years.

Menu 03 SET CHRONO

Press the "SET" button (3) and then button 5 to arrive at the desired menu; press "SET" (3) to enter. Enter menu M-3-1 and with buttons 1 and 2 select whether or not to activate the thermostat (on/off), which allows you to program the automatic ignition of the machine. Once the thermostat is activated/deactivated, press button "4" (OFF) and continue scrolling through the submenus using button 5. Select which submenu you wish to enter in order to access the daily, weekly, and weekend programmes.

To set the ignition times and days repeat the previous steps:

- access the submenu using "SET" (3)
- adjust the days, times, and activation status (on/off) with buttons 1 and 2
- confirm by pressing the "SET" button (3)
- exit from the submenu/menu with button 4 to turn it off

The following table briefly describes the structure of the menu, focusing only on those selections which are available to the user.

level 1	level 2	level 3	level 4	value
03 - set thermostat				
	01 - activate thermos.			
		01 - activate thermos.		on/off
	02 - day programme			
		01 - daily thermostat		on/off
		02 - start 1 day		hour
		03 - stop 1 day		hour
		04 - start 2 day		hour
		05 - stop 2 day		hour

level 1	level 2	level 3	level 4	value
03 - set thermostat				
	01 - activate thermos.			
		01 - activate thermos.		on/off
	02 - day programme			
		01 - daily thermostat		on/off
		02 - start 1 day		hour
		03 - stop 1 day		hour
		04 - start 2 day		hour
		05 - stop 2 day		hour
	03 - week program.			
		01 - week thermostat		on/off
		02 - start program. 1		hour
		03 - stop program. 1		hour
		04 - monday progr. 1		on/off
		05 - tuesday progr. 1		on/off
		06 - wednesday prog. 1		on/off
		07 - thursday prog 1		on/off
		08 - friday prog 1		on/off
		09 - saturday prog 1		on/off
		10 - sunday prog 1		on/off
		11 - start program. 2		hour
		12 - stop program. 2		hour
		13 - monday progr. 2		on/off
		14 - tuesday progr. 2		on/off
		15 - wednesday prog. 2		on/off
		16 - thursday prog 2		on/off
		17 - friday prog 2		on/off
		18 - saturday prog 2		on/off
		19 - sunday prog 2		on/off
		20 - start program. 3		hour
		21 - stop program. 3		hour
		22 - monday progr. 3		on/off
		23 - tuesday progr. 3		on/off
		24 - wednesday prog. 3		on/off
		25 - thursday prog 3		on/off
		26 - friday prog 3		on/off
		27 - saturday prog 3		on/off
		28 - sunday prog 3		on/off
		29 - start program. 4		hour
		30 - stop program. 4		hour
		31 - monday progr. 4		on/off
		32 - tuesday progr. 4		on/off
		33 - wednesday prog. 4		on/off
		34 - thursday prog. 4		on/off

Menu 03 SET CHRONO

Submenu 03 - 01 - activate thermostat

This allows you to activate and deactivate all of the functions of the thermostat

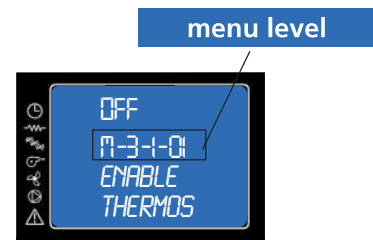

Submenu 03 - 02 - daily programme

This allows you to enable, disable, and set the daily functions of the thermostat.

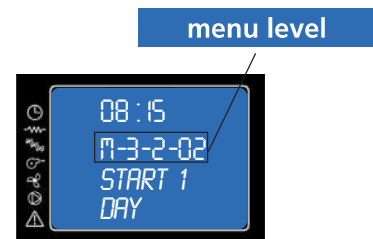

It's possible to set more operating ranges delimited by the times set according to the following table where the OFF setting tells the clock to ignore the command:

selection	meaning	possible values
START 1	activation time	hour - OFF
STOP 1	shut-off time	hour - OFF
START 2	activation time	hour - OFF
STOP 2	shut-off time	hour - OFF

Submenu 03 - 03 - weekly programme

This allows you to enable, disable, and set the weekly functions of the thermostat.

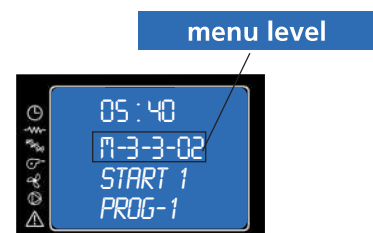

Plan programming carefully in order to avoid overlapping activation/deactivation times in a single day in different programmes.

PROGRAMME 1			
menu level	selection	meaning	possible values
02-03-02	START PROGRAM 1	activation time	time - OFF
02-03-03	STOP PROGRAM 1	shut-off time	time - OFF
02-03-04	MONDAY PROGRAM 1	reference day	on/off
02-03-05	TUESDAY PROG 1		on/off
02-03-06	WEDNESDAY PROG 1		on/off
02-03-07	THURSDAY PROGR 1		on/off
02-03-08	FRIDAY PROGRAM 1		on/off
02-03-09	SATURDAY PROGR 1		on/off
02-03-10	SUNDAY PROGR 1		on/off

PROGRAMME 2			
menu level	selection	meaning	possible values
03-03-11	START PROGRAM 2	activation time	time - OFF
03-03-12	STOP PROGRAM 2	shut-off time	time - OFF
03-03-13	MONDAY PROGRAM 2	reference day	on/off
03-03-14	TUESDAY PROG 2		on/off
03-03-15	WEDNESDAY PROG 2		on/off
03-03-16	THURSDAY PROGR 2		on/off
03-03-17	FRIDAY PROGRAM 2		on/off
03-03-18	SATURDAY PROGR 2		on/off
03-03-19	SUNDAY PROGR 2		on/off

PROGRAMME 3			
menu level	selection	meaning	possible values
03-03-20	START PROGRAM 3	activation time	time - OFF
03-03-21	STOP PROGRAM 3	shut-off time	time - OFF
03-03-22	MONDAY PROGRAM 3	reference day	on/off
03-03-23	TUESDAY PROG 3		on/off
03-03-24	WEDNESDAY PROG 3		on/off
03-03-25	THURSDAY PROGR 3		on/off
03-03-26	FRIDAY PROGRAM 3		on/off
03-03-27	SATURDAY PROGR 3		on/off
03-03-28	SUNDAY PROGR 3		on/off

PROGRAMME 4			
menu level	selection	meaning	possible values
03-03-29	START PROGRAM 4	activation time	time - OFF
03-03-30	STOP PROGRAM 4	shut-off time	time - OFF
03-03-31	MONDAY PROGRAM 4	reference day	on/off
03-03-32	TUESDAY PROG 4		on/off
03-03-33	WEDNESDAY PROG 4		on/off
03-03-34	THURSDAY PROGR 4		on/off
03-03-35	FRIDAY PROGRAM 4		on/off
03-03-36	SATURDAY PROGR 4		on/off
03-03-37	SUNDAY PROGR 4		on/off

Submenu 03 - 04 - program week-end

This allows you to enable, disable, and set the weekend functions of the thermostat (days 5 and 6, or Saturday and Sunday).

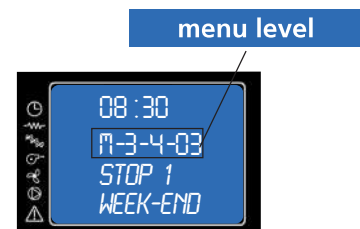

REMARKS:

- in order to avoid confusion and unwanted start-ups or shutdowns, activate only one programme at a time unless you know exactly what you'd like to achieve
- deactivate the daily program if you want to use the weekly program
- always leave the weekend programme deactivated if you use weekly programmes 1, 2, 3, and 4.
- activate the weekend programme only after you have deactivated the weekly programme.

Menu 04 - select language

Press the SET button to access the menu and press  (5) up to the MENU 04 - SELECT LANGUAGE. Then press the SET button to access the menu. Select the desired language using the keys  (1) e  (2)

Alarm signals

In the event of a working defect, the system informs the user about the type of failure occurred. The following table summarises the alarms, kind of problem and possible solution:

Display		Kind of problem	Solution
ALAR 1	BLACK OUT	There is no power supply	As soon as the power supply is back, the Hydro Insert starts a cooling cycle. After completing the cycle it starts working automatically
ALAR 2	PROBE EXHAUST	The smokes sensor is broken or not connected to the pcb	Contact an Authorized Assistance Center
ALAR 3	HOT EXHAUST	Smokes temperature too high	Switch off the Hydro Insert, allow it to cool down and perform ordinary cleaning. If the problem persists, contact an Authorized Assistance Center for cleaning the Hydro Insert and the flue
ALAR 4	FAN FAILURE	Smokes extractor blocked or broken	Contact an Authorized Assistance Center
ALAR 5	NO LIGHTIN	The Hydro Insert cannot start up This is the first light-up	Fill in the tank with pellets Start up again
ALAR 6	NO PELLET	The pellet Hydro Insert switched off while working	Fill in the tank with pellets
ALAR 7	SAFETY THERMAL	The water temperature exceeds 90°C. The circulating pump is blocked or there is no water in the hydraulic system	Check the power supply on the pump. Check limestone does not block the pump impeller
ALAR 8	FAILURE DEPRESS	Obstructed flue	Clean the flue or check there are no obstructed grids near the smokes exhaust
ALAR B	ERROR TRIAC COCLEA	The cochlea loads too much pellet	Contact an Authorized Assistance Center
ALAR C	PROBE WATER	Water probe faulty	Contact an Authorized Assistance Center
ALAR D	HOT WATER	Water temperature too high	Allow the Hydro Insert to cool down. If the problem persists, contact an Authorized Assistance Center and have the hydraulic system checked
ALAR E	PRESS WATER	Water pressure too high	Allow the insert to cool. If the problem persists, contact the Authorized Assistance Center
SERV		The Hydro Insert has worked for 1300 hours. Supplementary maintenance required	Contact an Authorized Assistance Center

Regular checks should be carried out by the user, who should only contact the Authorized Assistance Center if no solution is found.

Failure on electrical devices

Mancata accensione

If the flame does not light up during the switching on or if the smokes temperature does not reach a suitable value in the foreseen time gap, the Hydro insert switches off and you will read the words **"NO LIGHTIN"**.

on the display. Press the key "On/Off" to reset the alarm. Wait until the cooling phase is completed, clean the brazier and start a new light-up.

Switching off while working

The Hydro insert suddenly switches off while working (for example because it has run out of pellets in the tank or because the motor reducer for pellets loading got broken). The Hydro insert continues working until the pellets left in the brazier ends. You will then read the words **"NO PELLET"** on the display and the stove switches off. Press the key "On/Off" to reset the alarm. Wait until the cooling phase is completed. Clean the brazier and start a new light-up.

These alarms remind you that the brazier must be cleaned and installed correctly before switching on the Hydro insert.

There is no power supply

In the event of a power drop longer than one minute, the Hydro insert can exhaust some smoke in the room: this causes no risks. As soon as you have the power supply again, the Hydro insert will have the words **"BLACK OUT"** on the display.



Do not attempt to start the Hydro insert before the required time or it may get blocked. If this occurs, switch off the switch on the back of the pellet Hydro insert stove for 1 minute, set it on again and wait 10 minutes before starting the Hydro insert again.



The power socket where the Hydro insert is connected should be fitted with "earth connection complying with regulations in force." The Manufacturer shall not be held responsible for damage to things or people resulting from negligent installation.

Manual restart thermostat

Intervention in case of danger

In case of fire, disconnect the power supply, use a fire extinguisher in accordance with, and if necessary, call the fire department and then contact an authorised qualified technical assistance



Safety devices



Pressure switch: monitors depression in the smoke duct. It is designed to shut down the pellet feed screw in the event of an obstructed flue or significant back-pressure in the presence of wind. At the time of the pressure switch will show **"ALAR-DEP-FAIL"**.



Reduction motor: if the motor stops, the Hydro Insert continues to function until the flame goes out for lack of fuel, and until it has cooled down to the minimum level.

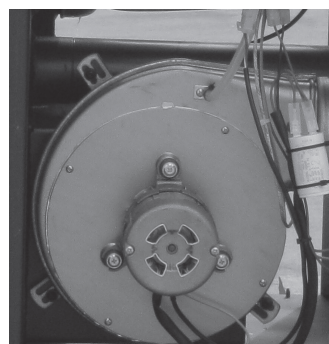

Flue gas temperature sensor: thermocouple that measures the temperature of the fumes while keeping the operation or shuts the Hydro Insert when the flue gas temperature drops below the preset value.

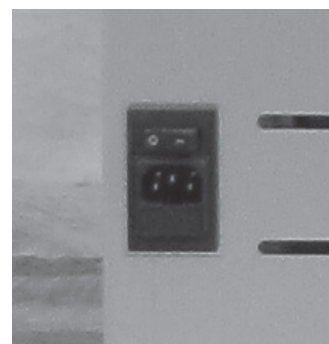

Electrical safety: the Hydro Insert is protected against violent surges of current (ex. lightnings) by the main fuse 4 A which is located on the control panel at the rear of the Hydro Insert. Other fuses to protect the electronic boards are to be found on the boards themselves.



Safety thermostat with manual reset for the water temperature: if the temperature of the water tank exceeds the preset safety level of 100 °C immediately stops the operation of the Hydro Insert and the display will show **"ALAR-SIC-FAIL"**. To restart you need to reset manually.



Water temperature probe: if the water temperature approaches the blocking temperature (100 °C), the probe requires to interrupt the supply of pellets.

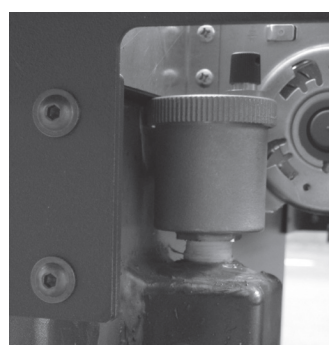

Automatic vent valve: this valve eliminates the air inside the Hydro Insert and of the heating system.



Safety valve: this valve acts to prevent over pressurization of the hydraulic system. If the pressure of the Hydro Insert or plant exceeds 2.5 bar it drains the water from the circuit.

Anti-freeze function: if the probe in the Hydro Insert detects a water temperature of less than 5°C, the circulation pump is automatically activated to keep the system from freezing.

Pump anti-seizure function: if the pump is not used for prolonged periods, it is activated periodically for 10 seconds, to prevent it blocks.



Tampering with the safety devices is prohibited. It is only after eliminating the cause which gave rise to the intervention of the safety system, that it is possible to relight the Hydro Insert and thus reset the automatic operation of the sensor. To understand which anomaly has occurred, consult this manual at paragraph relating to alarms which explains what to do based on the alarm message the Hydro Insert display.



All cleaning of all parts must be carried out with the Hydro Insert completely cold and unplugged to avoid burns and thermal shock. The Hydro Insert does not need much maintenance if used with certified quality pellet. The need for maintenance varies depending on the conditions of use (switching on and off repeatedly) and depending on the performance required. It is recommended periodic monitoring of the Hydro Insert to check its condition.

Parts	Everyday	Every 2-3 days	Every week	Every 15 days	Every 30 days	Every 60-90 days	Every 1 year
Brazier	◇						
Cleaning the ash collection compartment with suction device		◇					
Cleaning ash tray		◇					
Cleaning the interior heat exchanger / smoke fan compartment						•	
Cleaning complete exchanger							•
Clean "T" to exhaust						•	
Flue							•
Door gasket ash						•	
Internal parts							•
Flue pipe							•
Circulation pump							•
Hydraulic components							•
Electromechanical components							•

◇ by the user / • by the authorised qualified technical assistance

BY THE USER

Daily control

The Hydro Insert requires a simple and thorough cleaning in order to ensure a more efficient performance and smooth operation. While cleaning the inside of the Hydro Insert, to prevent the escape of ashes, you can start the fan flue exhaust. Clean the grate from the ash and any incrustation which could obstruct the passage of air. In the case of depletion of pellets in the tank may accumulate unburned pellets in the burn pot. Always empty the residuals from the grate before each start. Remember that only a brazier located and clean properly can ensure ignition and optimal operation of your Hydro Insert. When positioning the crucible, carefully check that the ends of the pads completely adhere to their home and that the hole with pipe dedicated to the passage of the resistance. There should be no residual combustion in the contact zone between the edges of the crucible and the support surface on the door crucible.



Controllo ogni 2-3 giorni Cleaning the ash collection compartment

Clean and empty the ash tray being careful with hot ash. The ash must be completely cold for a vacuum cleaner to be used to remove it. Only if the ash is completely cold, you can also use a canister vacuum cleaner suitable for picking up particles of a certain size.

Cleaning ash and combustion chamber including the spark plug lead.



Flame-shell cleaning

Cleaning of stainless steel and satin-finish surfaces

Normally these surfaces do not need to be treated, but if they do, avoid cleaning them with abrasive materials. For surfaces in stainless and satin brushed steel we recommend cleaning with a paper towel or a clean dry cloth moistened with a detergent based on non-ionic surfactants (<5%) A spray glass cleaner may be used.



Avoid contact with skin cleanser and eyes. In case this happens, sprinkle with plenty of water and contact the nearest medical center.

Cleaning of painted parts

Do not clean the painted parts with wet rags when the unit is in operation or hot to prevent thermal shock to the paint which may cause it to detach. Do not use abrasive or aggressive products or materials. Clean with damp cotton or paper towels. The silicon paints used by manufacturer possess technical characteristics that make them resistant

to very high temperatures. There is however a physical limit (380° C - 400° C) beyond which the paint begins to fade or (over 450°) to vitrify; it may then flake and detach from the steel surface. If this happens, it means that temperatures have been reached that are far above those at which the unit should operate properly.



Do not use abrasive materials or harsh. Clean with damp cotton or paper towels.

Lower ash drawer cleaning

Si raccomanda la pulizia del cassetto cenere dai residui caduti durante il funzionamento. Remove the grid, take out the tray, empty and clean the corners with a suction device.

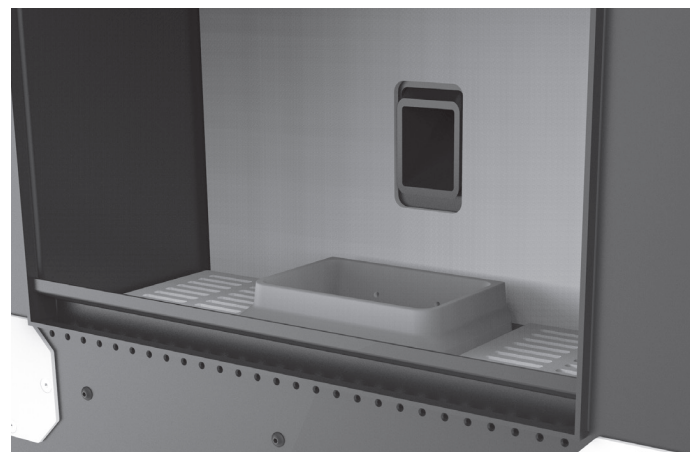

Shutting the Hydro insert down

In the period when the Thermostove is out of use it must be disconnected from the electricity mains. For greater safety, especially if there are children around, we recommend removing the power cable from the rear of the Hydro insert.

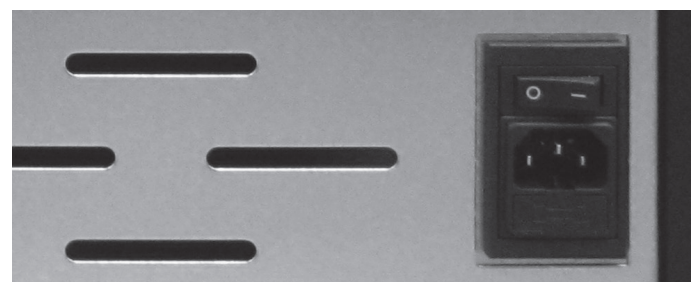

Before placing the Hydro Insert in storage, you should remove all pellets from the hopper with a vacuum cleaner with a long extension. If the fuel is left in the hopper, it may get damp, stick together, and be difficult to light at the beginning of the next season. If pressing the main switch (located on the back of the Hydro Insert) does not make the control panel display light up, it could mean that the service fuse needs replacing. On the rear of the Hydro Insert there is a fuse holding compartment which is located underneath the supply socket. With a screwdriver open the cover of the fuse holding compartment, and replace the fuse if necessary (3,15 AT delayed type). Plug the unit back in and press the main switch.

2 Extract the chimney insert using the appropriate handles and remove the protective casing.

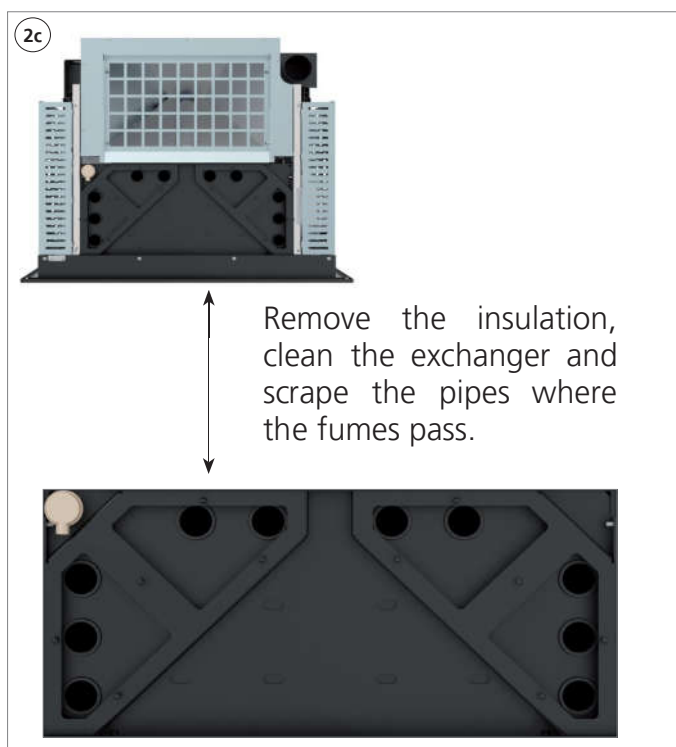
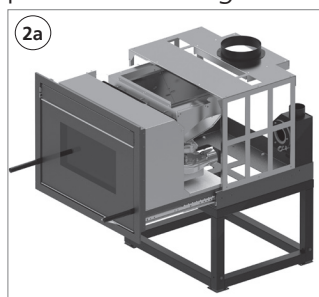

CLEANING BY THE TECHNICAL
Check every year

Compartment ventilation flue gas cleaning

Remove the fixing screws and remove the smoke fan for cleaning of the same. Perform the task with the greatest care not to bend the fan blades.

Exchanger cleaning

1 Remove the combustion chamber plate to remove it, push the plate upwards and then rotate it towards the front.

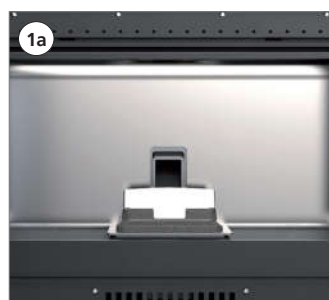

Clean the pipes behind the plate.

Clean flue

Clean the flue system especially near the fittings to "T", curves and any horizontal sections. Is necessary to check and remove any deposit of ash and soot before the same clogging the passage of smoke.

- ③ On the front there are two inspection plates, remove them and clean the compartment with an ash-cleaner.



For your safety, the frequency of cleaning the smoke discharge system must be determined on the basis of how the Hydro Insert is used.

In case of failure or inadequate cleaning of the heater may have function problems such as:

- poor combustion
- blackening of the glass
- clogging of grate with accumulation of ash and pellets
- ash deposit and excessive deposits on the heat exchanger resulting in poor performance.

The check of electromechanical components must be performed only by qualified personnel with technical knowledge of electricity and combustion. Once the cleaning operations have been completed, reassemble and fix the parts.

Warnings for cleaning

All cleaning of all parts must be carried out with the Hydro Insert completely cold and the plug disconnected.

Before effecting any maintenance operation or cleaning on the Hydro Insert, take the following precautions:

- be sure that all parts of the Hydro Insert are cold
- be sure that the ashes are completely cold;
- be sure that the general switch is in the "OFF" position;
- be sure that the plug is pulled out of the socket to avoid accidental contact;
- Once the maintenance phase is completed check that everything is in order as per before the intervention (the brazier is placed correctly).



Follow carefully the following cleaning instructions. Failure to follow these instructions could create problems with the operation of the Hydro Insert.

Any kind of tampering or unauthorized substitution of non-original of the Hydro Insert can be hazardous to the safety of the operator and relieves the manufacturer from any civil or criminal liability. Use only original spare parts. Replace a worn before failure promotes the prevention of injuries resulting from accidents caused by the sudden failure of the components.



After 1300 hours of operation of the heater will appear on the lower display the word "SERV", please contact your Authorized Service Center for cleaning and routine maintenance.



All repairs must be carried out exclusively by a specialised technician, with the Hydro Insert completely cold and the electric plug pulled out. Is prohibited from any unauthorized modification to the device and the replacement of parts with other non-original. The operations marked in bold type must be carried out by specialised personnel.

Check for proper combustion of the shape and color of the flame

PROBLEM	POSSIBLE CAUSE	REMEDY
The flame thickens at the base and the tip has not pulled upwards.	1. Bad regulation that determines: <ul style="list-style-type: none"> • Too full of pellets • Low fan speed 2. The duct is obstructed or there are pressures that hamper the smooth evacuation of fumes	1. Define the adjustment of the Hydro Insert 2. Clean the smoke duct and check the pressure switch that measures the proper depression of the chimney
Flame swollen and bursting with color from orange to yellow with dark tips	1. Combustion wrong 2. Flame oxygen deficient	1. Define the adjustment of the Hydro Insert 2. Make sure the air duct up to the brazier is not obstructed 3. Contact your Authorized Assistance Center

In normal combustion, the flame should have a tapered shape, compact, with character "lively" and with the tips tend to be vertical or crushed towards the back of the firebox. You have to have the feeling that the flame is pulled upwards.

Anomalies related to the scope mechanical or electronic

PROBLEM	POSSIBLE CAUSE	REMEDY
Pellet not being fed into the combustion chamber.	1. Pellet hopper empty 2. Feeder screw blocked by sawdust 3. Reduction motor defective 4. Defective electronic board 5. One of the thermostats with manual reset has tripped or the microswitch for extraction does not work	1. Refill pellet hopper 2. Empty the hopper and manually free the feeder screw of sawdust 3. Replace reduction motor 4. Replace electronic board 5. Reset on the back of the Hydro Insert the safety thermostat after verifying the cause
The Hydro Insert does not run	1. Plug out of place 2. Lack of electricity supply 3. Parameter suction power to change 4. Pellet or water sensor in lockout 5. Fuse blown 6. Obstruction of nests or foreign bodies in the chimney or fireplace	1. Check the correct position of the sparkplug in the grate 2. Check that the electric socket is plugged in and that the main switch is in position "I" 3. Contact your Authorized Assistance Center 4. Wait for the cooling of the pellets or water tank and turn on the Hydro Insert 5. Replace the fuse 6. Remove all foreign matter from the chimney or flue outlet of the barrel. It is recommended that the intervention of a chimney sweep

<p>The fire goes out or the Hydro Insert stops automatically</p>	<ol style="list-style-type: none"> 1. Pellet hopper empty 2. Pellets not being fed in 3. Intervention of pellet temperature sensor 4. Door not closed properly or gaskets worn 5. Hydro Insert temperature is too high 6. Unsuitable pellets 7. Low pellet feed rate 8. Combustion chamber dirty 9. Smoke outlet obstructed 10. Smoke extraction motor failed 11 Pressure switch faulty or defective 	<ol style="list-style-type: none"> 1. Refill pellet hopper If it is first ignition the fuel, having to go the route that goes from the tank to the brazier, may not be able to arrive on time and in the right amount programmed 2. If after repeated ignitions did not appear in the flame, even with regular supply of pellets, the problem may be related to the components of the heater or the improper installation 3. Let the Hydro Insert cool down completely, reset the thermostat till lockout ceases, relight Hydro Insert; if problem persists, contact technical assistance 4. Close the door or replace the gaskets with original spare parts 5. Check for proper operation of the water pump, if necessary, replace the component 6. Change to a type of pellet recommended by the manufacturer 7. Have the fuel feed rate checked by technical service 8. Clean the combustion chamber, following instructions in the manual 9. Clean the smoke duct 10. Check the motor and replace if necessary 11. Replace the pressure
<p>The Hydro Insert runs for a few minutes and then goes out.</p>	<ol style="list-style-type: none"> 1. Lighting cycle not completed 2. Temporary failure of electricity supply. 3. Smoke duct obstructed. 4. Temperature sensors defective or broken. 5. Sparkplug failure. 	<ol style="list-style-type: none"> 1. Re-run lighting cycle 2. See previous instruction 3. Clean smoke duct 4. Check and replace sensors as necessary 5. Check the plug and replace if necessary
<p>Pellet build up in grate, door glass gets dirty and flame is weak</p>	<ol style="list-style-type: none"> 1. Insufficient combustion air 2. Pellets damp or unsuitable 3. Smoke extractor motor broken 4. Bad adjustment. Wrong ratio between air and pellet 	<ol style="list-style-type: none"> 1. Check that the room air intake is present and free. Check that the pipe Ø 5 cm for air inlet is not obstructed. Clean the grate and check that all the airways are clear. Carry out a general cleaning of the combustion chamber and the smoke duct. Check the state of the door gaskets 2. Change the type of pellet 3. Check the motor and replace if necessary 4. Contact your Authorized Assistance Center
<p>The smoke extraction motor does not work</p>	<ol style="list-style-type: none"> 1. No electrical supply to the Hydro Insert 2. The motor is broken 3. Defective electronic board 4. Control panel broken 	<ol style="list-style-type: none"> 1. Check the supply voltage and the protection fuse 2. Check the motor and capacitor and replace if necessary 3. Replace electronic board 4. Replace the control panel
<p>The air fan convention never stops</p>	<ol style="list-style-type: none"> 1. Temperature sensor temperature control defective or broken 2. Fan failure 	<ol style="list-style-type: none"> 1. Check operation of the sensor and replace if necessary 2. Check operation of the motor and replace if necessary

In the automatic position the Hydro Insert always runs at full power	<ol style="list-style-type: none"> 1. Room thermostat set to maximum 2. Temperature sensor defective 3. Control panel defective or broken 	<ol style="list-style-type: none"> 1. Reset the thermostat temperature 2. Check the operation of the sensor and replace if necessary 3. Check the panel and replace if necessary
The Hydro Insert starts up "alone"	<ol style="list-style-type: none"> 1. Incorrect programming of the cronothermostat 	<ol style="list-style-type: none"> 1. Check the settings of the cronothermostat
The power does not change even if you manually adjust	<ol style="list-style-type: none"> 1. The board is set to automatic correction of power in proportion to the temperature 	<ol style="list-style-type: none"> 1. Contact your Authorized Assistance Center

Anomalies related to the plumbing circuit

PROBLEM	POSSIBLE CAUSE	REMEDY
No increase in temperature with Hydro Insert in operation	<ol style="list-style-type: none"> 1. Incorrect combustion adjustment 2. Hydro Insert/system dirty 3. Insufficient Hydro Insert power 	<ol style="list-style-type: none"> 1. Check parameters 2. Check and clear the Hydro Insert 3. Check that the Hydro Insert is properly sized for the requirements of the system
Condensation in Hydro Insert	<ol style="list-style-type: none"> 1. Incorrect setting maximum water temperature in the Hydro Insert 2. Insufficient fuel consumption 	<ol style="list-style-type: none"> 1. Set the Hydro Insert to a higher temperature. The maximum water temperature in the Hydro Insert is 65 ° C and can not be set below 40° C or above 80 ° C. It is advisable to never adjust the temperature below 60 ° C to avoid condensation in the Hydro Insert. Adjust the power of the pump at a higher temperature to 60 ° C. 2. Contact your Authorized Assistance Center
Radiators cold in winter but the Hydro Insert boils	<ol style="list-style-type: none"> 1. Circulator does not run because blocked 2. Radiators have air in them 	<ol style="list-style-type: none"> 1. Free up the circulator by removing the plug and turning the shaft with a screwdriver. Check the electrical connections of the same, replace if necessary 2. Vent the radiators
Hot water in not provided	<ol style="list-style-type: none"> 1. Circulator pump blocked 	<ol style="list-style-type: none"> 1. Free the circulator pump
The Hydro Insert boils under "modulation" that reaches the temperature set on the thermostat of the Hydro Insert	<ol style="list-style-type: none"> 1. It 'been set to a value of thermostat too high 2. It was set too much power to the implant. 	<ol style="list-style-type: none"> 1. Lower the temperature in the Hydro Insert 2. Reduce the value of operating power

<p>The Hydro Insert goes into "modulation" as it reaches the temperature set on the thermostat of the Hydro Insert even at low temperatures of the water in the Hydro Insert</p>	<ol style="list-style-type: none"> 1. Modify the parameter for the maximum smoke temperature modulation to edit 2. Dirty Hydro Insert: the fumes are too high temperature. 	<ol style="list-style-type: none"> 1. Contact your Authorized Assistance Center 2. Clean the tube bundle
--	--	--



**Never turn off the heater by removing electricity.
Let always complete the shutdown cycle, otherwise you may damage the structure and have trouble lighting in the future.**

GENERAL GUARANTEE

All products are subject to accurate testing and are covered by warranty for 24 months from the date of purchase, documented by invoice or purchase receipt that will be presented to authorized technicians. If the document does not show up, it will be invalidate the right of the owner of the appliance. Warranty means the replacement or repair of parts of the appliance that are defective at source due to manufacturing faults.

1. Warranty covering manufacturing defects and defects in material declines:

- for unauthorized personnel work;
- for damage caused by transport or for causes not attributable to the manufacturer;
- for incorrect installation;
- for incorrect electrical connection;
- for periodic maintenance not performed;
- for outdoor accidents (lightning, floods, etc ...);
- for incorrect use and maintenance.

2. Complete replacement of the machine can only take place following the unquestionable decision by the manufacturer in special cases

3. The Company declares no responsibility for any damage that may, directly or indirectly, result in persons, things or animals as a result of non-observance of the instructions in the Instructions book and in particular concerning the installation, use and maintenance of the appliance.

GUARANTEE LIMITATIONS

Limited Warranty covers manufacturing defects, provided that the product has not been damaged by improper use, improper handling, incorrect connection, tampering, and installation errors. The following components are covered by a twelve months warranty:

- combustion burners;
- resistance.

They are not covered by warranty:

- the glass of the door;
- general gasket and fiber door;
- painting;
- tiles;
- the remote control
- Internal sides
- Any damage caused by inadequate installation and / or shortages of the consumer.

The images are purely indicative and may not match the reality of the product. Pictures are only exemplary and they are needed to understand how the product works.

